

ALUCOLUX[®]

PRE-COATED SOLID ALUMINIUM PANELS

Aesthetic, durable and non-combustible.

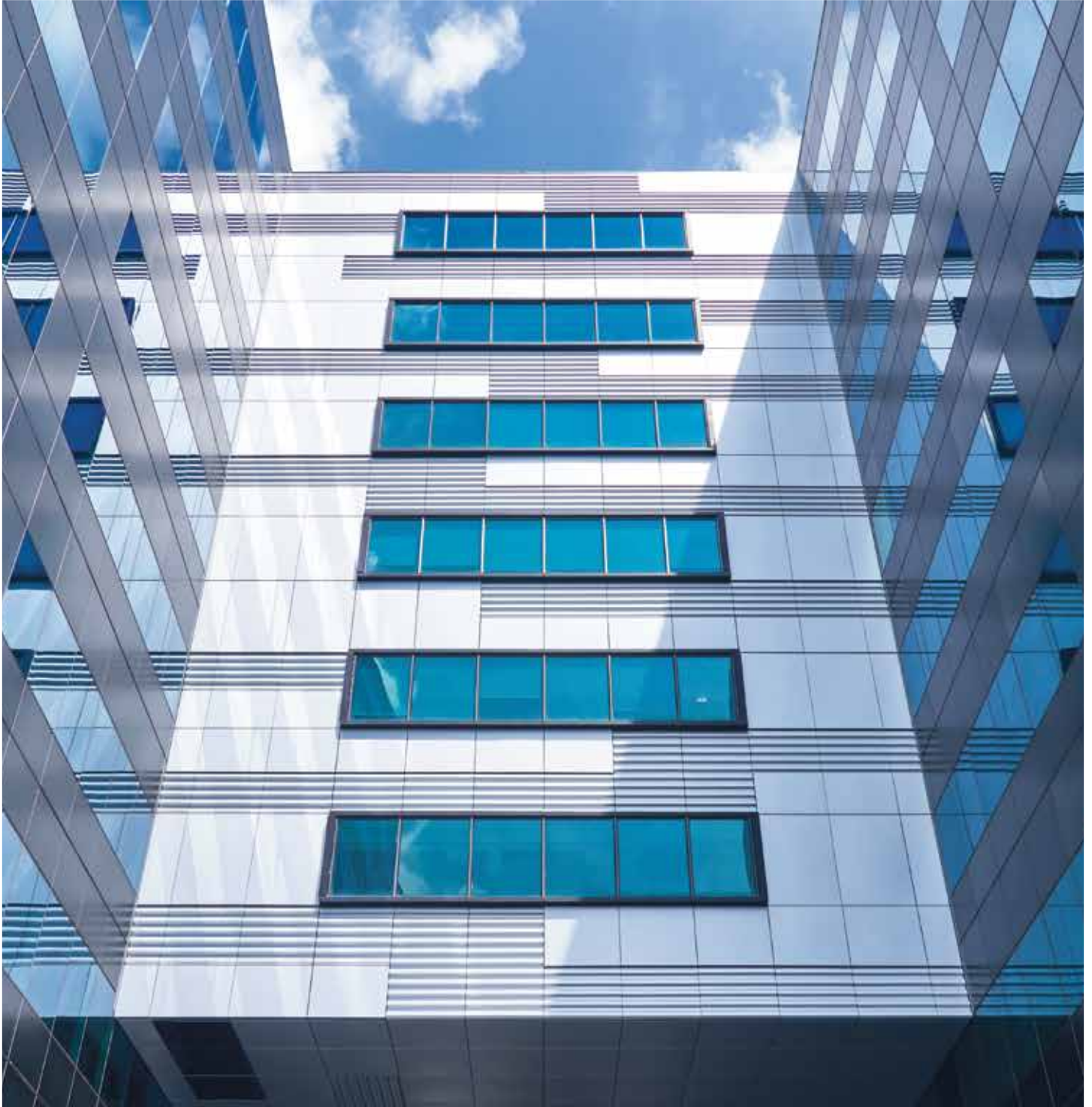



TABLE OF CONTENTS

About Us	05
The Product	06
Value Added Services	08
Fixing Systems	10
Technical Data	11
Cleaning and Maintenance	13
Storage and Transportation	13

ESR BIZPARK
Changi, Singapore



ABOUT US

As a global leader in composite materials, with its head office in Switzerland, affiliated with Schweiter Technologies Group, 3A Composites employs more than 4400 people in Europe, America and Asia. Presently, 3A Composites is a house to 20+ leading brands in their respective material and application categories. Amongst them, the flagship product lines used in architectural applications are:

ALUCOLUX® Solid Aluminium Sheets (cladding & curtain walls, interior walls, ceilings, soffits & column decoration)

ALUCOBOND® Aluminium Composite Material (cladding & curtain walls, interior walls, ceilings & column decoration)

ALUCORE® Aluminium Honeycomb Panels (cladding & curtain walls, roofing & ceilings)

TELEPARK
Singapore



30 MAIDEN
New Zealand



THE PRODUCT

ALUCOLUX® is a coil coated solid aluminium panel used in architectural applications.

ALUCOLUX® features multi-coat, multi-bake process on a continuous coil coating line using the highest grade of PVDF/FEVE paint system. This process not only ensures colour consistency and long-term durability but also renders it non-combustible.

Unique patterns resembling the look & feel of a real wood and stone are also possible with ALUCOLUX®.

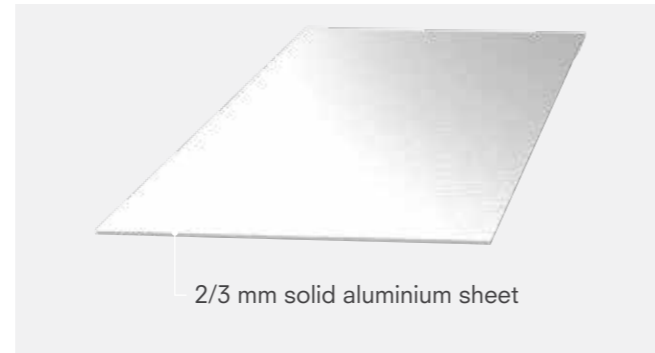

Product Range:

- Thickness: 2 or 3 mm
- Width: 1000 mm, 1250 mm, 1500 mm, 1575 mm
- Length: \leq 6000 mm

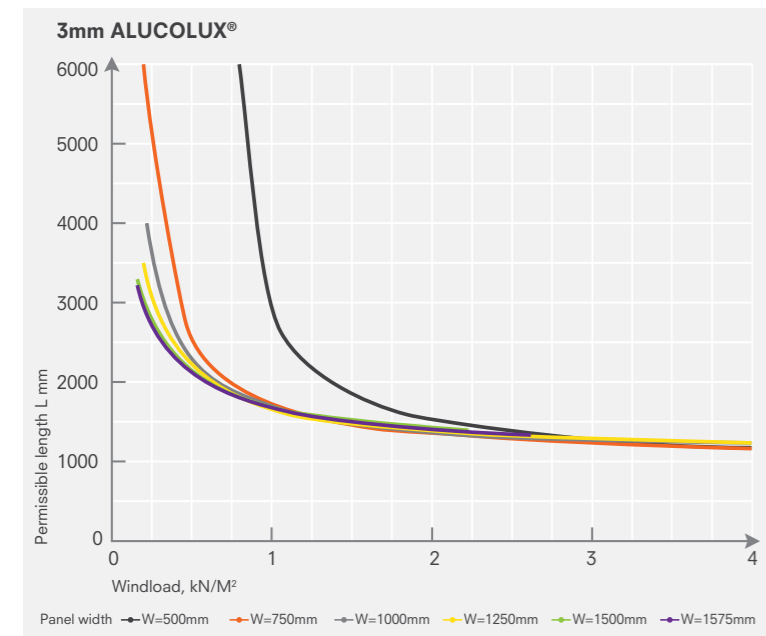

Wind load and permissible panel sizes

The diagram indicates the available range of panel sizes and permissible range lengths at a given panel width, depending on the wind load applied.

The diagram apply to panels supported on four sides (corners fixed). Dimensional values for other systems are available on request.

Leed Certification

The LEED program has gained much recognition over the past several years and is now the premier sustainability design tool in the building industry. LEED focuses on constructing buildings that have

minimal impact on the environment during construction and occupation and acknowledges that using recycled materials is an essential part of reducing environmental deterioration.

Material	Thickness (mm)	Weight (kg/m ²)	Recycled % Pre-Consumer	Recycled % Post Consumer	LEED Contribution (1.0 x Post + 0.5 x Pre)
ALUCOLUX®	3	8.1	20%	20%	30%

The solid aluminium panels used for cladding traditionally are manufactured using the post-painting system, where mill-finished aluminium sheets are first fabricated and then put through a batch-coating process with spray or powder coating method. The batch-coating is done under a less controlled environment compared to the highly industrial coil-coating process.

Batch-coating leads to an inconsistent thickness of the paint layer across the surface resulting in colour inconsistencies on the panels.

Batch-coated or powder-coated panels fail to qualify as non-combustible due to the extra thickness of the paint coat on the surface. They are usually classified as A2 and not A1 as per EN 13501-1 test standard.

Batch-coated panels also face limitations in terms of panel sizes, the variety of colours and surface finishes thereby limiting designers' choices.

Moreover, there are 2 to 3 different vendors involved in getting the final product ready, resulting in a split accountability towards quality.

REASONS TO CHOOSE ALUCOLUX®



Color consistency

High quality PVDF/FEVE coating on a continuous industrial grade coil-coating line conforming to AAMA 2605 and ECCA guidelines.



Perfect flatness

The alloy and temper used in the manufacturing of ALUCOLUX® is specifically chosen to ensure that the finished product has perfect flatness.



Non-combustible

A non-combustible panel which has passed a larger system test BS 8414-1 and is classified as A1-s0,d0 as per EN 13501-1 test standard.



Formability

ALUCOLUX® is a solid and rigid aluminum panel, yet highly formable.



Range of colours

ALUCOLUX® comes in a vast range of colors and surface finishes, giving you a large variety to choose from.



Technical support

You get support from 3A Composites team in recommendation and designing of appropriate fixing systems or any other necessary assistance.



Recyclability

ALUCOLUX® is 100% recyclable material.



Warranty

ALUCOLUX® comes with a 15-year warranty.



TIMBERLY ROAD
Auckland, New Zealand

VALUE ADDED SERVICES

We have always tried to offer complete solutions to our customers apart from just world-class products.

Through Value Added Services (VAS) we go a step further to ensure that our customers get high-quality fabrication and finesse in the final output.

Made to Measure (M2M) Panels:

We can manufacture tailor-made panels which are cut to size, routed, drilled and notched at the factory's production level to meet customers' specific requirements. This helps in high-quality fabrication and warrants a smooth transition from flat sheet to final product.

Ready to Install (R2I) Panels:

R2I is a step further over the M2M service with folding and system assembly coming from the house of 3A Composites itself. R2I allows for direct delivery at the job site. This ensures hassle-free installation and refined end product.

Whether the customer needs made to measure, ready to install or perforated panels, all could come directly from the factories of 3A Composites.

Perforation:

According to your project's requirements we also offer perforation service as design customization. Skillful workmanship of 3A Composites coupled with years of expertise ensures warrantable high-quality output.

Below are some examples of how ALUCOLUX® can be fabricated at our plant, thereby saving on wastage and reducing the overall cost of the project.



ESSR BIZPARK
CHANGI, SINGAPORE



DISTRICT SECRETARIAT
GAMPAHA
SRI LANKA

FIXING SYSTEMS

Tray Panel

This system is one of the most adaptable systems for facade cladding with either vertical or horizontal panel layouts. Individual panels are tray/cassette type, with four sides folded and framed with extruded aluminium profile sections. Individual elements are fastened to an extruded aluminium sub-structure

by means of aluminium profiled cleats, which in turn are anchored to the wall. The horizontal and vertical joints between the panels are of minimum 15 mm width and all rivets, fastening cleats and screws are concealed within it and kept closed by a profiled strip of matching or contrasting colour.

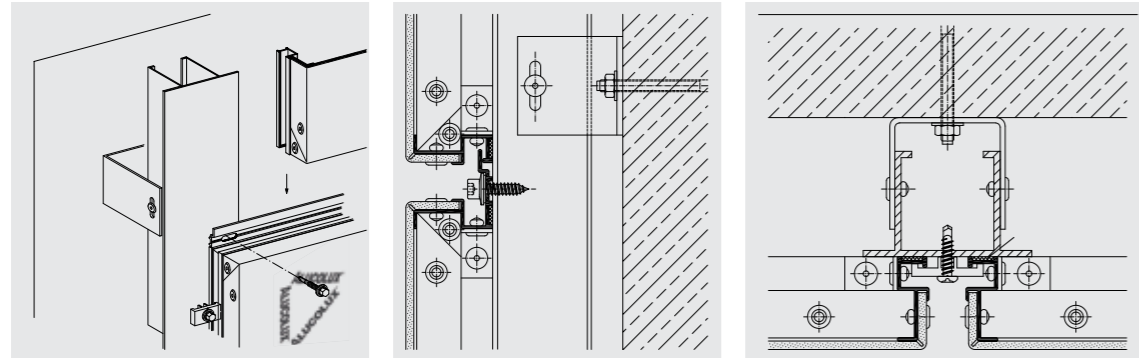

SZ-20

This system assembly is based on the 'tongue and groove' principle and is particularly suited for facade cladding with a horizontal panel layout. Individual panels are folded into a tray and the top and bottom sides are grasped by an extruded aluminium section. The 'Z' and 'S' profiles are riveted to the top and bottom folded edge of the panels respectively,

facilitating the 'tongue and groove' assembly. The vertical folded edges are riveted with the 'S' profiles that facilitate fixing with aluminium profiled cleats to the 'Hat' profiled sub-structure. All the rivets, fastening cleats and screws are concealed within the panels.

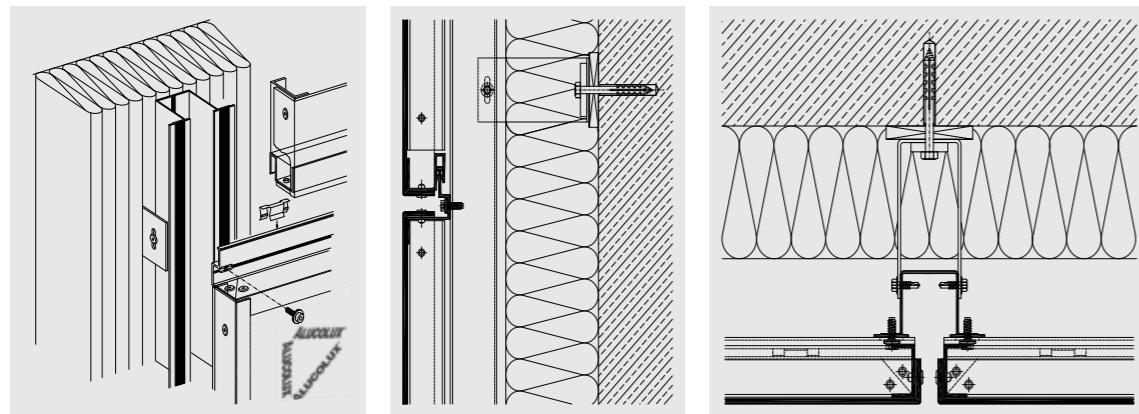

Hook-on

The ALUCOLUX® Hook-on system is an open-joint rear ventilated system with a vertical panel layout. This system facilitates un-impeded movements of

the elements in all aspects, as well as allowing the joint widths between the panels to be as narrow as 6 mm.

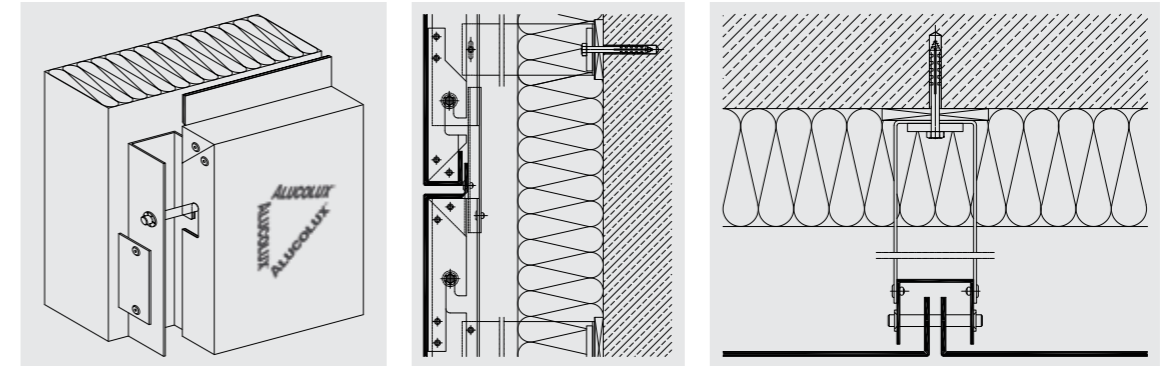

TECHNICAL DATA

TECHNICAL PROPERTIES	STANDARDS	COIL-COATED
Alloy	EN 573-3	3003
Temper	EN 515	H24
Standard Thickness*	EN 485-4	3mm
Standard Widths**	EN 485-4	1000 mm, 1250 mm, 1500 mm, 1575 mm
Standard Length	EN 485-4	<= 6000mm
Panel Weight		8.1 Kg/m ²
Tensile Strength	EN 485-2	145-185Mpa
Modulus of Elasticity	EN 485-5	70,000 N/mm ²
Yield Strength Rp0.2	EN 485-2	>=115Mpa
Elongation	EN 485-2	A ₅₀ >=6%
Linear Expansion	EN 1999 1-1	2.4mm/m at 100°C temperature difference
Surface		PVDF/FEVE
Gloss	EN 13523-2	25-40%
Coating Thickness ***		28-45 microns
Fire Classification	EN 13501-1 AS 3837 AS 1530.3 AS 1530.1 BS 8414-1	A1-s0, d0 Group 1 as per AS 5637.1 PASSED 0 (ignitibility) 0 (flame spread) 0 (heat evolved) 2 (smoke development) PASSED PASSED

* Other thicknesses available on request.

** Custom widths available on request.

*** Coating thicknesses varies for different surface finishes.

**TE PUHINUI STATION
INTERCHANGE**
Auckland, New Zealand

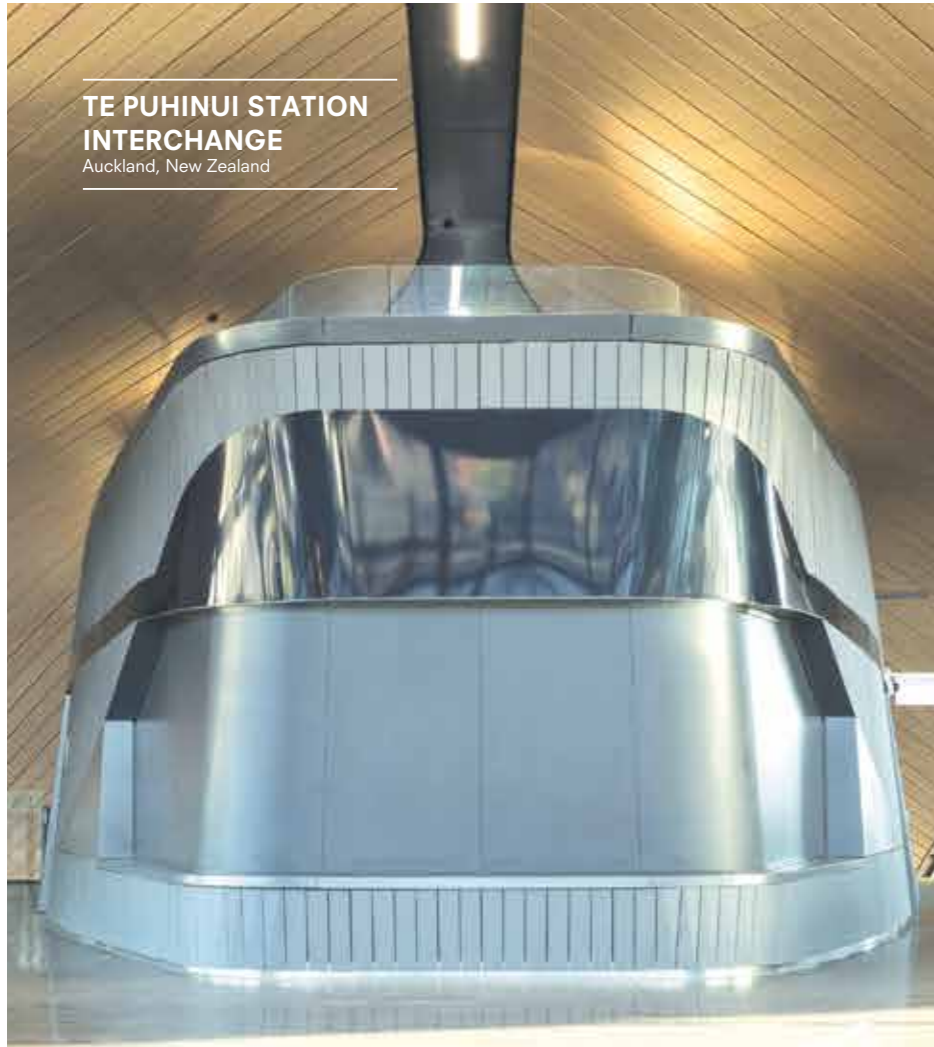

HECO ASCOT HOSPITAL
Auckland, New Zealand



CLEANING & MAINTENANCE

Annual cleaning is recommended. The surfaces should be cleaned either manually using a soft brush or by means of a high-pressure cleaner (maximum 50 bar) with clean water. If necessary, a mild cleaning agent (pH 6-7) may be added up to a maximum of 10%. Cleaning should take place from top to bottom. After cleaning, rinse with clean water to remove any cleaning agent residue. Do not clean surfaces heated by the sun (>40° C).

Do not use highly alkaline cleaning agents such as potassium hydroxide, sodium carbonate, caustic soda, any strong acid products or highly abrasive cleaning agents such as household cleaning products that can corrode the paint.



STORAGE & TRANSPORTATION

To protect ALUCOLUX® panels against mechanical damages and harmful effects of weather conditions the following should be observed:

- Ensure careful handling of pallets during transport and unloading.
- Examine the pallets thoroughly upon arrival for any damages due to transportation.
- Stack only three pallets of similar dimensions horizontally above one another with the heaviest at the bottom. Do not let the panels stand vertically.

TIMBERLY ROAD
Auckland, New Zealand





3A Composites Asia Pacific Pte. Ltd.

300 Beach Road
#10-06 The Concourse
Singapore 199555
☎ (65) 6303 9750
✉ sales@alucobond.com.sg
🌐 www.alucobond.com.sg

3A Composites India Pvt. Ltd.

39th Floor, Commerz III,
International Business Park,
Oberoi Garden City,
Off Western Express Highway,
Goregaon (East), Mumbai - 400 063
☎ (91) 22 4256 4500
✉ alucobond.india@3acomposites.com
🌐 www.alucobond.in

3A Composites USA

721 Jetton Street, Suite 325
Davidson, NC 28036
United States of America
☎ (1) 800 626 3365
✉ info.usa@3acomposites.com
🌐 www.alucobondusa.com

3A Composites Middle East (Branch)

Almas Tower, JLT
P.O. Box: 343522
Dubai, UAE
☎ (97) 1 58 535 1721
✉ basel.massis@3acomposites.com
🌐 www.alucobond.com

3A Composites Gmbh

Alusingenplatz 1
78224 Singen
Germany
☎ (49) 7731 941 2060
✉ info@alucobond.com
🌐 www.alucobond.com

Alucobond Composites (Jiangsu) Ltd.

10 South Hehuan Road
Zhonglou District
Changzhou, China - 213023
☎ (86) 519 8166 5766
✉ alucobond.china@3acomposites.com
🌐 www.alucobond.com.cn