

# ALUCODUAL®

## PROCESSING AND TECHNICAL DATA

Simply original, originally simple

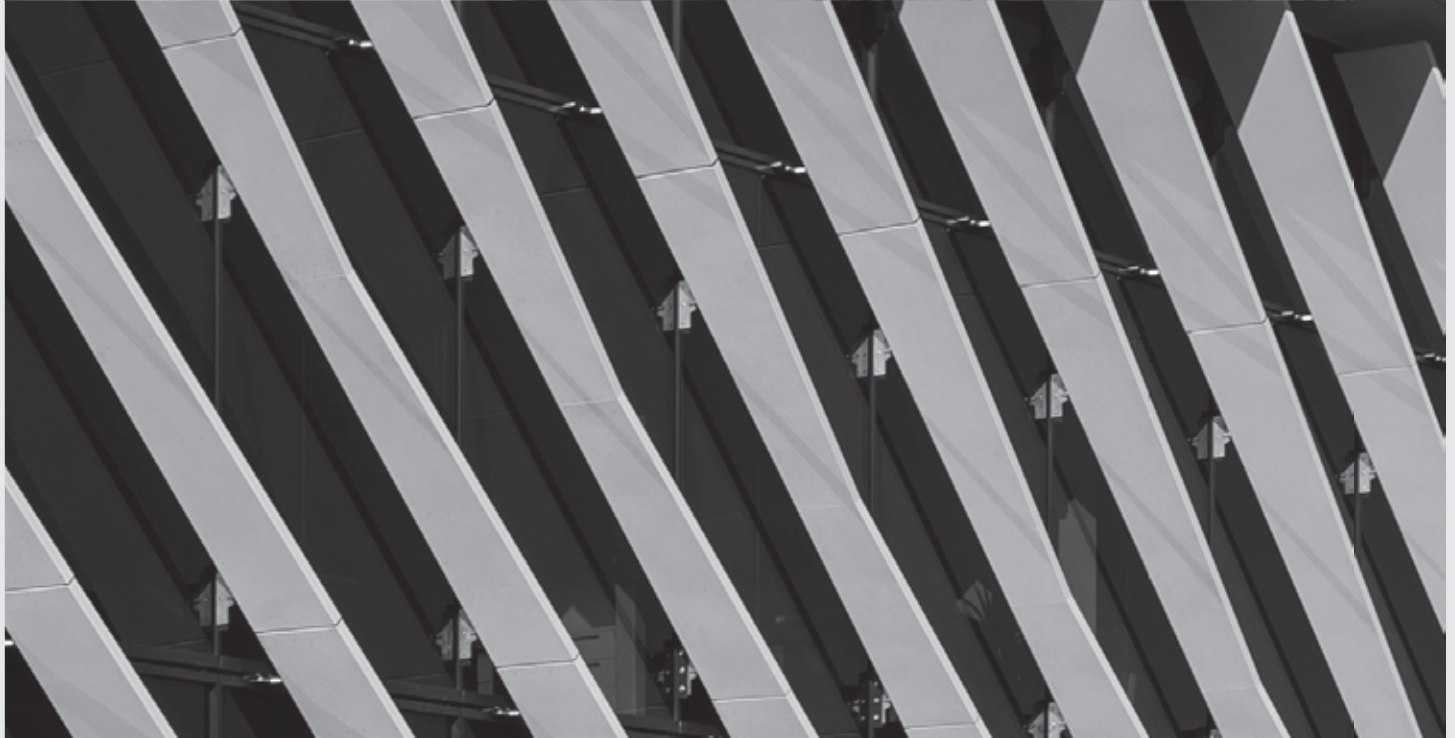

# CONTENTS

---

## **TRANSPORTATION, STORAGE**

4 General

## **PANEL DIMENSIONING**

5 General

## **INFORMATION ON SPECIAL SURFACES**

6 General

## **PANEL FIRE RESISTANCE CHARACTERISTIC**

6 General

## **PROCESSING AT A GLANCE**

7 General

8 Machines/Tools used for processing

## **PROCESSING METHODS**

11 Fixing Stiffeners

12 Notching/Punching

13 Routing Process

13 Routing Using CNC Router

14 Drilling & Cutting

14 Bending

15 Perforation

15 Cleaning & Maintenance

## TRANSPORTATION, STORAGE

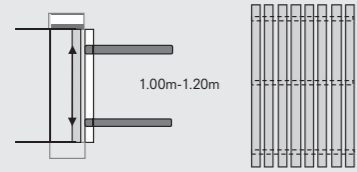

Set maximum fork width



Pick up the pallet, slightly raise the fork

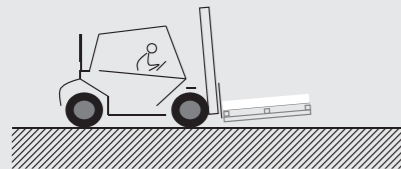

Pick up the complete pallet, neither draw nor push

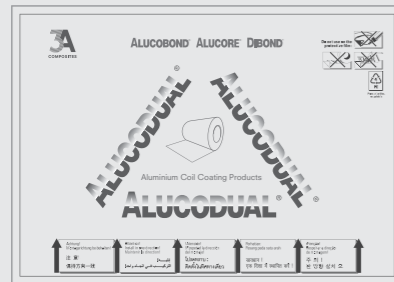

Protective film with direction arrows

### GENERAL

To protect ALUCODUAL® Engineered Solid Sheets from mechanical damage and weather, please follow the instructions thoroughly:

- Handle the pallets with utmost care during transportation and loading.
- Upon delivery, examine the pallets for any damage due to transportation or moisture.
- Any panels that are exposed to moisture must be dried to avoid spots or corrosion. In case of damages please report it to the respective forwarding agent.
- Store the pallets away from moisture, rain or any other form of contact with water or liquids. Avoid condensation when moving the panels from colder to warmer rooms.
- Stack only three pallets of similar dimensions horizontally above one another with the heaviest at the bottom. Do not let the panels stand vertically.
- While lifting, do not slide the panels over each other to avoid scratches. The panels must be carried by two people securely holding all four corners with gloves to avoid staining.
- Do not put anything between two panels while stacking, to avoid markings.

To ensure optimum care from the protective film please follow the instructions thoroughly:

- Storing the panels for more than three months may render the protective film tough to remove. Exposure to direct sunlight or fluctuations in temperatures could reduce the durability of the film.
- Do not mark the protective film with inks (markers), tapes or labels. The solvent or plasticizer may penetrate the film and affect the lacquered surface.
- Partial peeling of the protective film may cause dirtying of the edges that could affect its bounding property.
- Remove the protective film not longer than 45 days after the assembly. Exposure to natural elements may make it difficult to remove later.
- Do not remove the protective film at temperatures under 0°C.

## PANEL DIMENSIONING

### WHEN DIMENSIONING THE ALUCODUAL® PANELS

#### THE FOLLOWING SHOULD BE NOTED:

- Width: 1250mm, 1500mm
- Length:  $\leq 6000$ mm
- Thickness: 2mm/2.5mm/3mm

### Dimensional Tolerance

Items	Panel Size (mm)	Allowable Tolerance
Thickness (mm)	2, 2.5 & 3	$\pm 0.2$
Width	upto 1575	+ 4mm
Length	< 4000	+ 5
	> 4000	+ 10
Surface Defect	No irregularities such as roughness, buckling and other imperfections with specification of visual inspection rules	

### Diagonals Difference

The difference between two diagonals shall not exceed the values contained in the table below.

Length (mm)		Thickness (mm)	Differences between diagonals, for the following widths (mm)		
From	Up to		Up to 1000	1001-1500	1501-1575
1000	2000	2 to 4	3	4	5
2001	3000		4	5	6
3001	6000		5	7	8

## INFORMATION ON SPECIAL SURFACES

There are two types of coatings on surface of ALUCODUAL® panels - PVDF and FEVE.

### Surface Properties

Dry Film Property	Test Method	Criteria
Colour Retention	ASTM D2244-93	Max 5 units after 4000 hrs. (exposed skin)
Gloss Retention	ASTM D523-89	70% after 4000 hrs. (exposed skin)
Chalking	ASTM D414-89	Max 8 units after 4000 hrs. (exposed skin)
Salt Spray	ASTM D-B117-90 NCCA 11-2	Blisters-10 (exposed skin) Scribe-8 3000 hrs., 35°C
Humidity-Thermal	ASTM D2246-65	No blister (exposed skin) No cracking 10 cycles: 24 hrs X 100%RH, 37.8°C; 2 hrs X 18°C; 4 hrs. X 24°C
Humidity	ASTM D2247-94	No change (exposed skin) 3000 hrs.-aluminium, 35°C
Condensing Humidity	ASTM D4585-87	None to very few #8 blisters (exposed skin) 100% RH X 54.4°C, 2500 hrs
Pencil Hardness	ASTM D3363-92a	2H (exposed skin)
Dry Wet Boiling Water	Method 8	No change (exposed skin) No change after 37.8°C, 24 hrs. No change after 100°C, 20 min
Impact Resistance	NCCA 11-5	No picking off after reverse impact cross-hatch test (panel)
Abrasion Resistance	ASTM D 968-93	Resisting 20 litres of falling sand. 20 litres is the criterion of AAMA; 70 litres/mil as the actual value

## PANEL FIRE RESISTANCE CHARACTERISTIC

ALUCODUAL® is a pre-coated engineered solid sheet comprising 2/3 layers of laminated aluminium skins. It is classified as Class A2-s1, d0 according to EN 13501-1 test standard, making it suitable for projects with stringent fire safety requirements.

To maintain high product quality, ALUCODUAL® gets continuous industrial-grade PVDF/FEVE coating. This process renders it non-combustible in compliance with the A2 classification.

## PROCESSING AT A GLANCE

Below are the general guidelines on processing - ALUCODUAL® Pre Coil-Coated Solid Aluminum Alloy Panels

### ALUCODUAL® Processing guidelines at a glance:

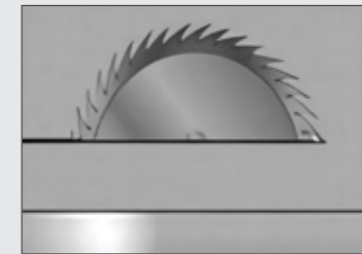

Sawing



Cutting



Routing



Routing & Folding



Pressing

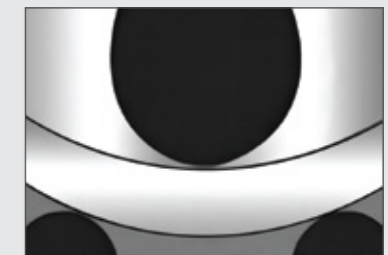

Rolling



CNC Routing

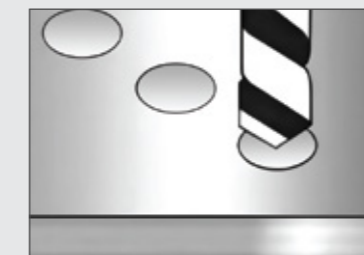

Drilling

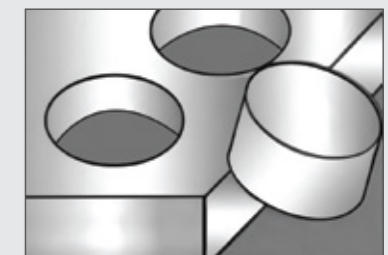

Perforation

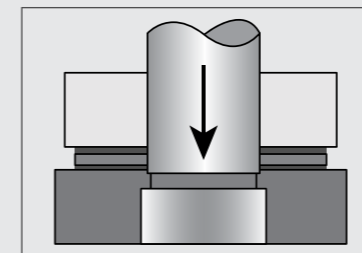

Punching and Notching

## Machines/Tools used for processing

To cut ALUCODUAL® sheets to required size the following machinery is recommended:

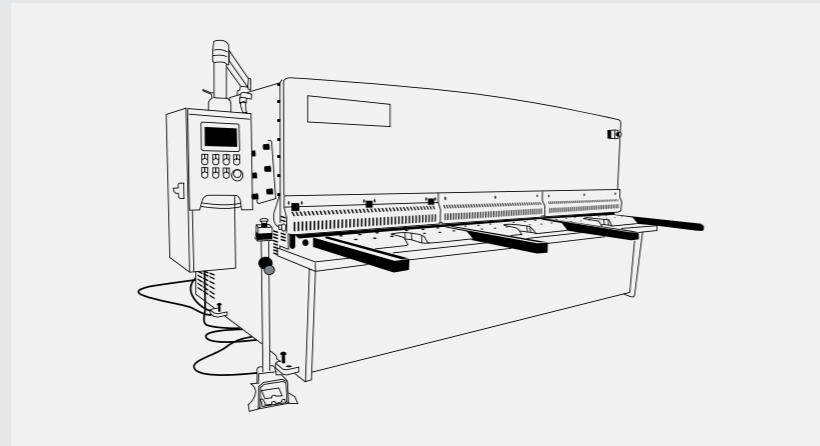
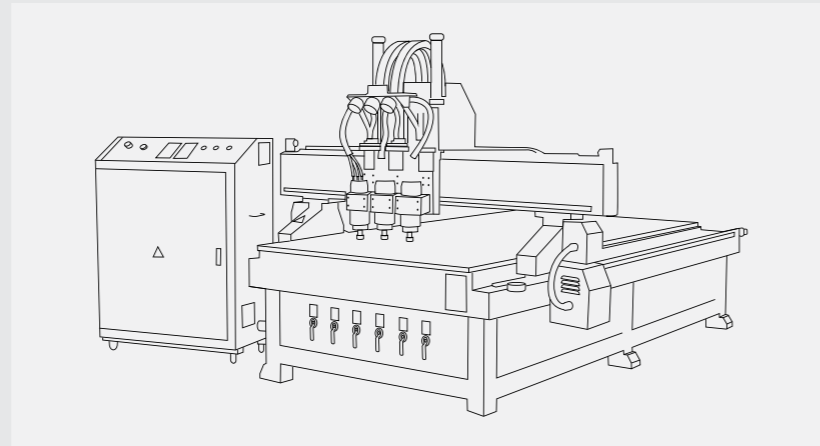
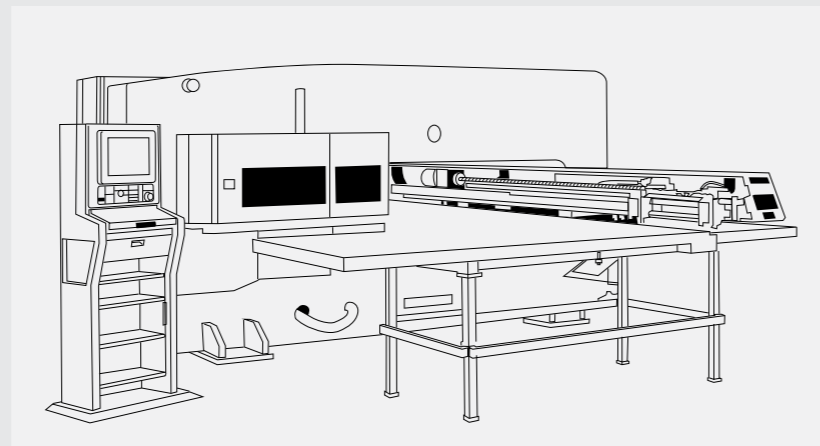

Plate Shearing Machine



Computer Numerical Control Router (CNC)



Numerical Control Turret Punch Press (NCT)

## Machines/Tools used for processing

CNC is usually used for routing, grooving, drilling and cutting ALUCODUAL®.

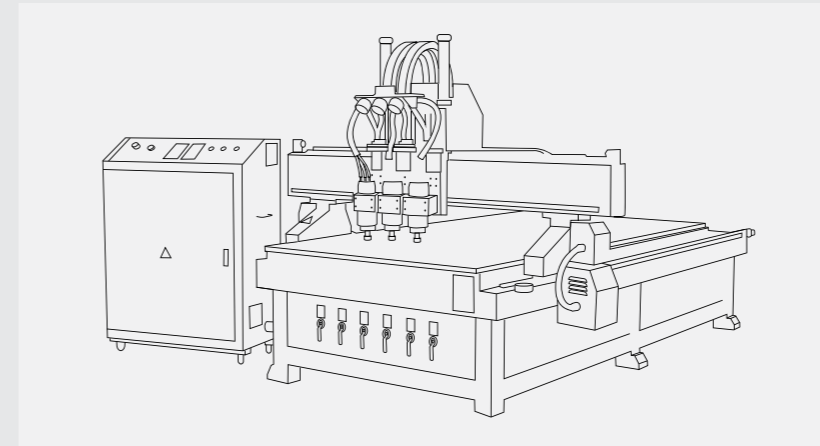

3-Axis Simultaneous-Motioned Numerical Control Carving Machine (CNC Router) with vacuum absorption worktable (as above).  
Or Simultaneous-Motioned double roller compaction worktable (as below).

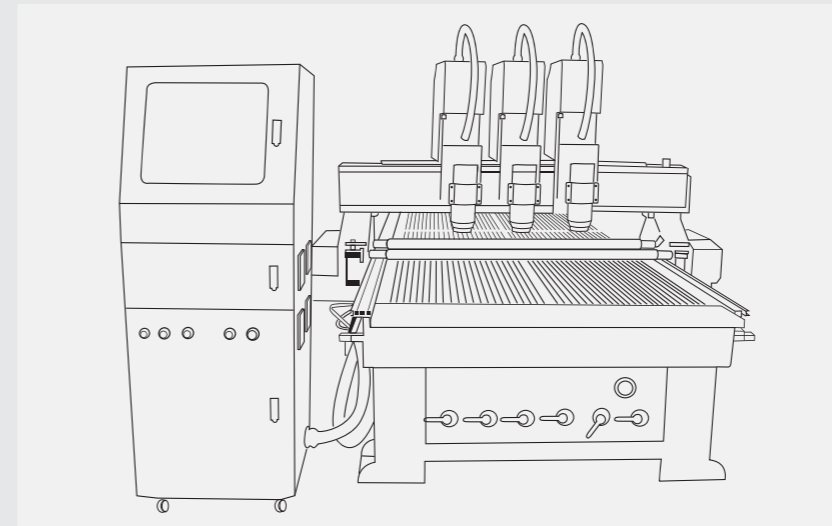

The 3-Axis Simultaneous-Motioned CNC has three blade holders and can change blades automatically during processing. Different blades perform separate processes, thus improving the efficiency of batch fabrication.

## Machines/Tools used for processing



### Parameters of CNC Router

CNC Type:	3-Axis Simultaneous-Motioned CNC Router
Worktable Type:	Vacuum absorption/Double roller compaction
Worktable Size (mm):	2000mm (W) X 6000mm (L)
Max. Processing Size (mm):	1900mm (W) X 6000mm (L) X 50mm (H)
Max. Feeding Speed (m/min):	8m/min.
Max. Bit Rotating Speed (rpm):	25000rpm.
Machine Precision (mm):	0.05mm
Spindle Tools:	Φ 6 Routing/Drilling Bits recommended
Type of Spindle Tools:	Tungsten Steel/Alloy Steel/Diamond Bit

### Advantage

- Heavy-duty machine structure guarantees solidity and the absence of vibrations resulting in high-precision processing.
- High-power air-cooling spindle with programmable rotation speed up to 25000rpm.
- The closed-loop control of position, speed and torque improves precision.
- The use of an emulsifier reduces the heat and noise significantly while protecting the equipment and the product.
- Z-axis is provided with a brake system to avoid damage to the working table and the product if the spindle falls off suddenly.
- Three blade holders are mounted on the portal frame of the working table to enable most complex multi-tool tasks effectively and automatically.

### Remark

- There are no mandatory provisions in relevant standards on routing depth back of aluminium panels. They mainly depend on practical application and processing experience as below:
- The recommended routing depth for 3mm ALUCODUAL® panel
  - For PVDF coating: Not over 2mm.
  - For FEVE coating: Not over 2.5mm.

## PROCESSING METHODS

### Fixing Stiffeners

Purpose: To weld stiffener rib to fix brackets.  
Tool: Grinder, Arc stud welding gun, Riveting gun, Socket spanner

Stiffeners should be fixed to the back of the panel based on the size of each panel and wind load calculations of the project site. The distance between stiffeners should not be more than 600mm. The stiffeners can be stud-welded or stuck using VHB tapes at the back of the panel.

If in case it is stud-welded, then it should be done using the right stud-welding tool.

Recommended depth of the welding: Between 1.5mm-2.3mm on a 3mm ALUCODUAL® panel.

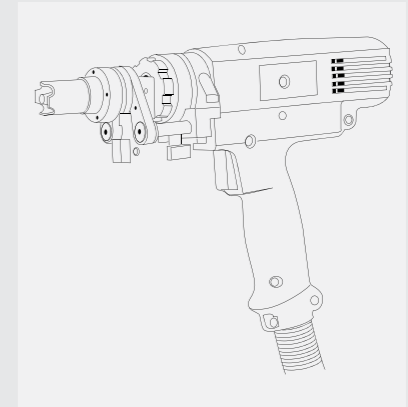

Arc stud welding gun

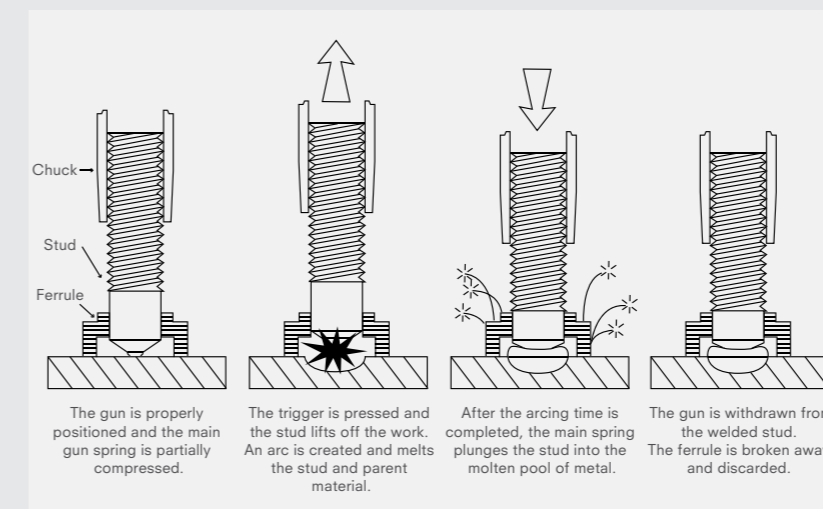

- Normally, the backside of the ALUCODUAL® sheet has a protective primer coat. Therefore, use the grinder to clean or polish the spots that need welding on the rear of the ALUCODUAL® tray panel.
- Position the stiffener rib and keep a 2mm gap between the folded edges.
- Weld the aluminium screw stud in the centre of the slot hole on the stiffener with the arc stud welding gun.
- Tighten the nuts.
- Remove the protective film from the folded edges before fixing the brackets.
- Rivet the fixing brackets to folded edges of the ALUCODUAL® panel with a pneumatic rivet gun.



## Notching/Punching

ALUCODUAL® panel can be notched/punched using conventional sheet metal punching machines. For clean cuts use sharp tools and die with a minimum cutting clearance of 0.1mm.

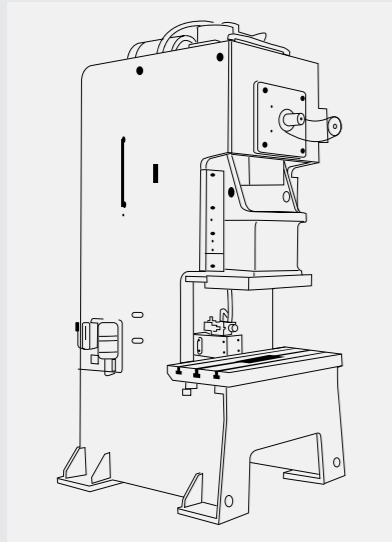

Folding: To form tray panels or other shapes, use a hydraulic folding machine of radius 3mm-5mm.

Before starting the fabrication process make sure the temperature of ALUCODUAL® is between 30°C to 40°C.

This could be done by using electric blankets, heating films or by pouring warm water onto the panel or dipping it in the warm water bath.

- Install a plunger chip and a press die according to the length of the edges to be folded.
- Add cushioning on the press die to prevent the edges from getting damaged.
- Fold the edges along the routed/grooved lines using a break press or edge folding machine.
- Measure the folded angles with a right-angle gauge.

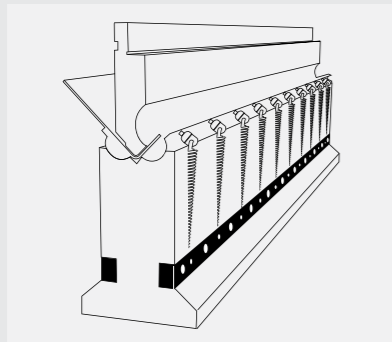

90° Blade Plunger Chip & Press Die

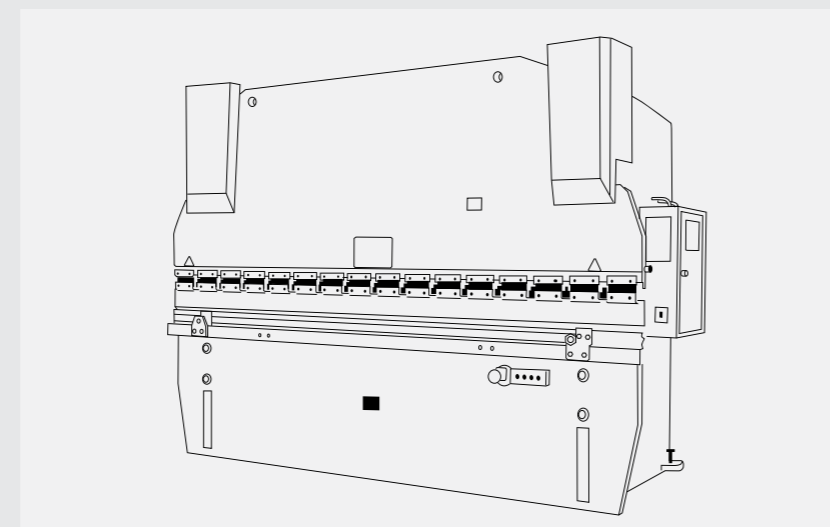
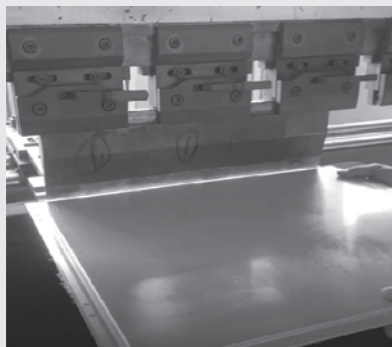

Hydraulic Folding Machine

## Routing Process

Purpose: The V-Groove are routed on the rear of the ALUCODUAL® sheet to form a tray panel.

Tool: V-Shaped Milling Cutter - 90°/120°/135° bits

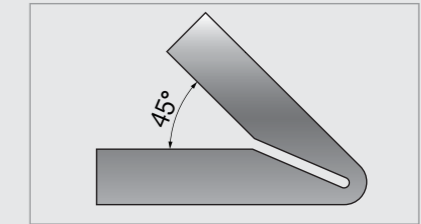
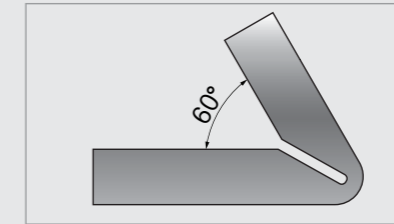
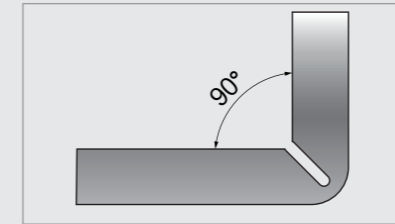
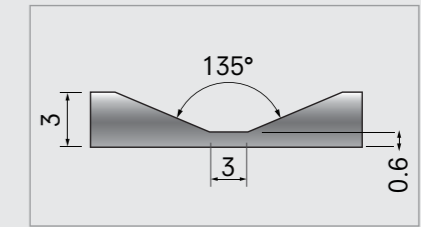
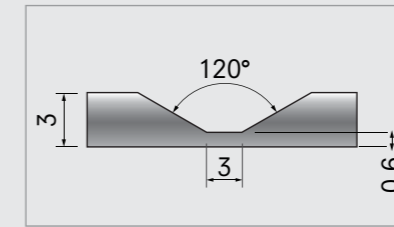
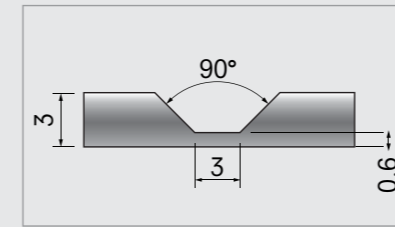

- Clean the platform to protect the surface of ALUCODUAL®.
- Place the ALUCODUAL® panel on the platform and position the starting point for routing. The CNC will process it according to the prepared routing path/diagram converted from the tray panel fabrication drawings.

## Routing Using CNC Router

- Place the routing tool in the spindle.
- Install the pressure foot assembly on Z plate.
- Adjust the depth of routing as per your requirement by adjusting nose rider threads.
- Take trial run & measure the depth of routing & adjust the tool depth if necessary.

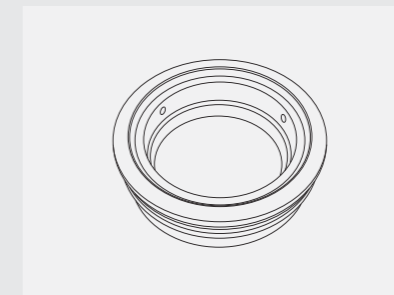
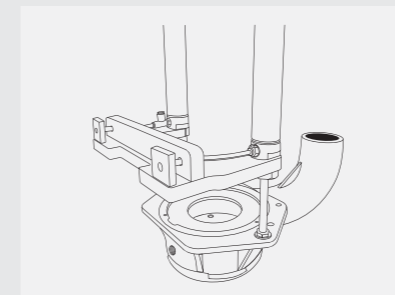

## Drilling and Cutting

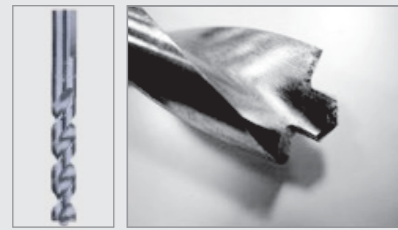

Purpose: Drilling holes and cutting.  
Tool: Drill Bit - To drill into the ALUCODUAL® panels the use of an Extreme 2TM HSS-G metal drill bit is recommended.

The V-Shape Milling Cutter gets replaced with a drilling bit automatically on completion of the routing process.

- $\Phi$  4.2mm staggered holes are drilled for fixing angle brackets.
- Machine cuts along the perimeter to form an M2M (Made to Measure) ALUCODUAL® panel.
- Clean the panel and platform with a low-pressure air blower.

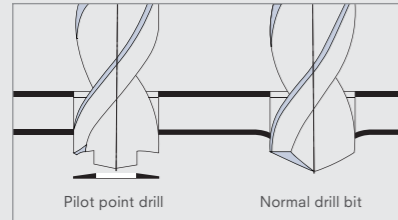

Use emulsifiers to reduce heat & noise and to protect the equipment and the product.

## Bending

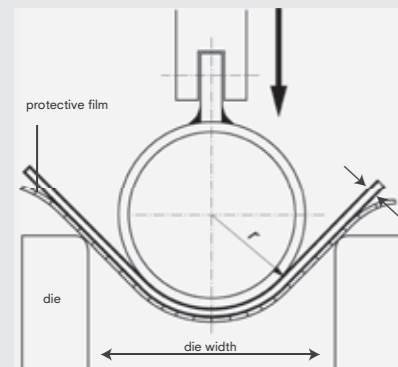

Bending with a brake press

- Bending of ALUCODUAL® can be done by using a roll bending machine.
- This can be done using three or four-roll machines.
- The panel to be bent is clamped between two cheeks.
- The projecting edge is bent around the upper clamping cheek or former using the movable swivel bar.
- The bending radius is determined by interchangeable formers attached to the upper clamping cheek.
- Minimum bending radius:  $r=400\text{mm}$

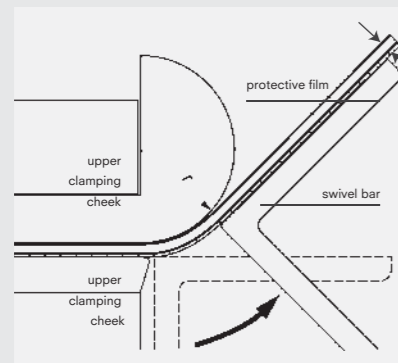

Bending with a folding machine

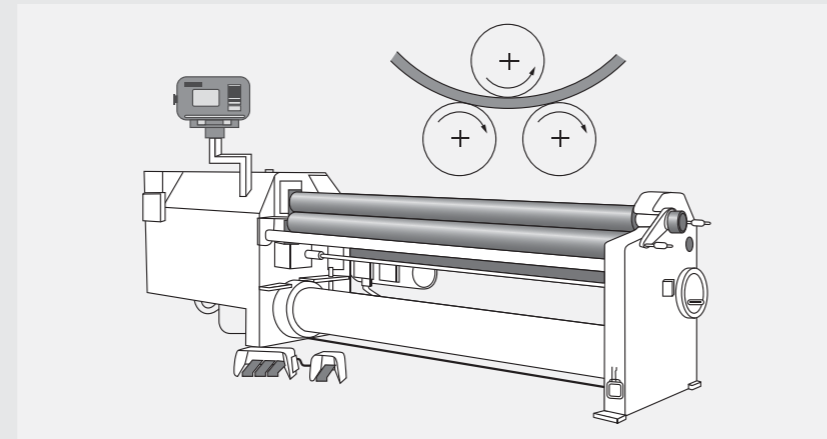

## Perforation

Perforation can be done using CNC or NCT machines in various designs and patterns as required.

- Holes of a minimum 3mm diameter can be punched.
- Minimum gap between the holes (measured from edges) should be greater than the thickness of the panel.
- When using the NCT machine for perforation, spray the emulsifier on the panel surface in advance to protect the equipment, punch tools and the surface coat.

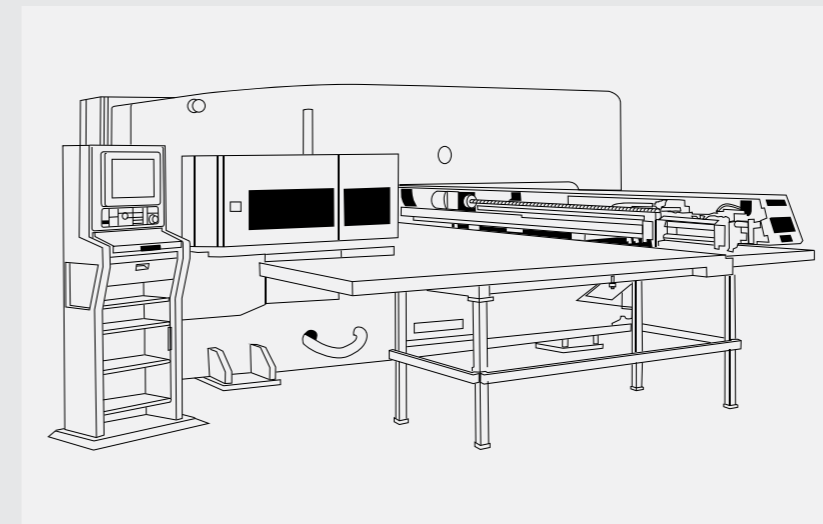

## Cleaning and Maintenance

Annual cleaning is recommended. The surfaces should be cleaned either manually using a soft brush or using a high-pressure cleaner (max. 50 bar) with clean water. If necessary, a mild cleaning agent (pH 6-7) may be added, up to a maximum of 10%. Cleaning should take place from top to bottom. After cleaning, rinse with water to remove any residue that could be left behind by a cleaning agent. Do not clean surfaces heated by the sun ( $>40^{\circ}\text{C}$ ). Do not use highly alkaline cleaning agents such as potassium hydroxide, sodium carbonate or caustic soda, any strong acid products or highly abrasive cleaning agents such as household cleaning products that could corrode the paint.

Next & Beyond.  
**ALUCOBOND®**

**3A Composites Asia Pacific Pte. Ltd.**

300 Beach Road  
#10-06 The Concourse  
Singapore 199555  
☎ (65) 6303 9750  
✉ sales@alucobond.com.sg  
🌐 www.alucobond.com.sg

**3A Composites India Pvt. Ltd.**

39th Floor, Commerz III,  
International Business Park,  
Oberoi Garden City,  
Off Western Express Highway,  
Goregaon (East), Mumbai - 400 063  
☎ (91) 22 4256 4500  
✉ alucobond.india@3acomposites.com  
🌐 www.alucobond.in

**3A Composites GmbH**

Alusingenplatz 1  
78224 Singen  
Germany  
☎ (49) 7731 941 2060  
✉ info@alucobond.com  
🌐 www.alucobond.com

**3A Composites Middle East (Branch)**

Almas Tower, JLT  
P.O. Box: 343522  
Dubai, UAE  
☎ (971) 58 535 1721  
✉ basel.massis@3acomposites.com  
🌐 www.alucobond.com

**Alucobond Composites (Jiangsu) Ltd.**

10 South Hehuan Road  
Zhonglou District  
Changzhou, China - 213023  
☎ (86) 519 8166 5766  
✉ alucobond.china@3acomposites.com  
🌐 www.alucobond.com.cn

**3A Composites USA**

721 Jetton Street, Suite 325  
Davidson, NC 28036  
United States of America  
☎ (1) 800 626 3365  
✉ info.usa@3acomposites.com  
🌐 www.alucobondusa.com

