

Next & Beyond.
ALUCOBOND®

ALUCOBOND®

AT ITS CORE

Unravelling the range



3A Composites Asia Pacific Pte. Ltd.

300 Beach Road
#10-06 The Concourse
Singapore 199555
☎ (65) 6303 9750
✉ sales@alucobond.com.sg
🌐 www.alucobond.com.sg

3A Composites India Pvt. Ltd.

Bldg. No. 11, Unit No. 1112, 1st Floor
Solitaire Corporate Park
Mathuradas VasANJI Marg
Andheri (East)
Mumbai - 400 093, India
☎ (91) 22 4256 4500
✉ alucobond.india@3acomposites.com
🌐 www.alucobond.in

3A Composites USA

721 Jetton Street, Suite 325
Davidson, NC 28036
United States of America
☎ (1) 800 626 3365
✉ info.usa@3acomposites.com
🌐 www.alucobondusa.com

3A Composites Middle East (Branch)

Almas Tower, JLT
P.O. Box: 343522
Dubai, UAE
☎ (971) 58 535 1721
✉ basel.massis@3acomposites.com
🌐 www.alucobond.com

3A Composites GmbH

Alusingenplatz 1
78224 Singen
Germany
☎ (49) 7731 941 2060
✉ info@alucobond.com
🌐 www.alucobond.com

Alucobond Composites (Jiangsu) Ltd.

10 South Hehuan Road
Zhonglou District, Changzhou
China - 213023
☎ (86) 519 8166 5766
✉ alucobond.china@3acomposites.com
🌐 www.alucobond.com.cn

JAN2025/SEA.





ALUCORE® | Max Towers – Noida, India
Architect: Gensler | Fabricator: Ashbee Industries India Pvt. Ltd.
Photography: Rohit Kumar



Index

About The Company:

- About Us ——— 06
- Environment, Social & Governance ——— 08
- Why Choose ALUCOBOND® ——— 10

Product Section:

- ALUCOBOND® A2 ——— 14
- ALUCOBOND® PLUS ——— 16
- ALUCOBOND® FR ——— 22
- ALUCORE® HONEYCOMB ——— 24
- ALUCORE® ACCP ——— 30
- ALUCORE® CLAD ——— 32
- ALUCOLUX® ——— 34
- ALUCODUAL® ——— 38
- SANDWICH PANEL SYSTEM ——— 40
- PRODUCT RANGE ——— 42

Value Added Services ——— 46

Fixing Systems ——— 48

Useful Information ——— 49

- Installation
- Protective Film
- Cleaning And Maintenance
- Storage
- Warranty

About Us



As a global leader in composite materials, with its head office in Switzerland, affiliated with Schweiter Technologies Group, 3A Composites employs more than 4600 people in Europe, America and Asia. Presently, 3A Composites is a house of 46+ leading brands in their respective material and application categories. Among them, the flagship product lines used in architectural applications are:

ALUCOBOND® Aluminium Composite Material (cladding & curtain walls, interior walls, ceilings, column decoration)

ALUCORE® Aluminium Core Panels (cladding & curtain walls, roofing & ceilings)

ALUCOLUX® Solid Aluminium Sheets (cladding & curtain walls, interior walls, soffits, ceilings and column decoration)

ALUCODUAL® Engineered Solid Sheets (cladding & curtain walls, interior walls, soffits, ceilings and column decoration)



Alusuisse developed the first Aluminium Composite Material in collaboration with BASF and named it ALUCOBOND®



ALUCOBOND® production commenced at the Alusuisse facility in Singen, Germany



Second site began the production of ALUCOBOND® in Benton, Kentucky, USA



Third ALUCOBOND® manufacturing base started production in Shanghai, PRC

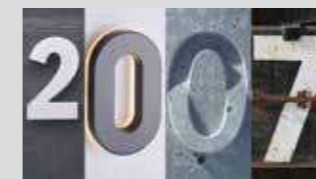

Inception of the fourth ALUCOBOND® manufacturing base in Pune, India

Environment, Social & Governance

Environment

3A Composites targets continuous improvement in areas such as environmental impact, energy consumption, waste management and production. We have developed and implemented environmental management systems which are regularly certified by third-party auditors. Having been successfully and continuously re-certified since 2006 speaks for itself.

Social

Being a global player, regional talents and skills are employed worldwide with an emphasis on professional development, health and safety. 3A Composites has developed a number of protocols,

procedures and programs to ensure guidelines are followed across the group. In addition, 3A Composites strives to be an active and responsible community member across all the locations worldwide.

Governance

Good, fair and ethical corporate governance is practised globally for sustainable and profitable growth. 3A Composites has a company-wide code of conduct which applies to all, from the board of directors to group management and all employees.

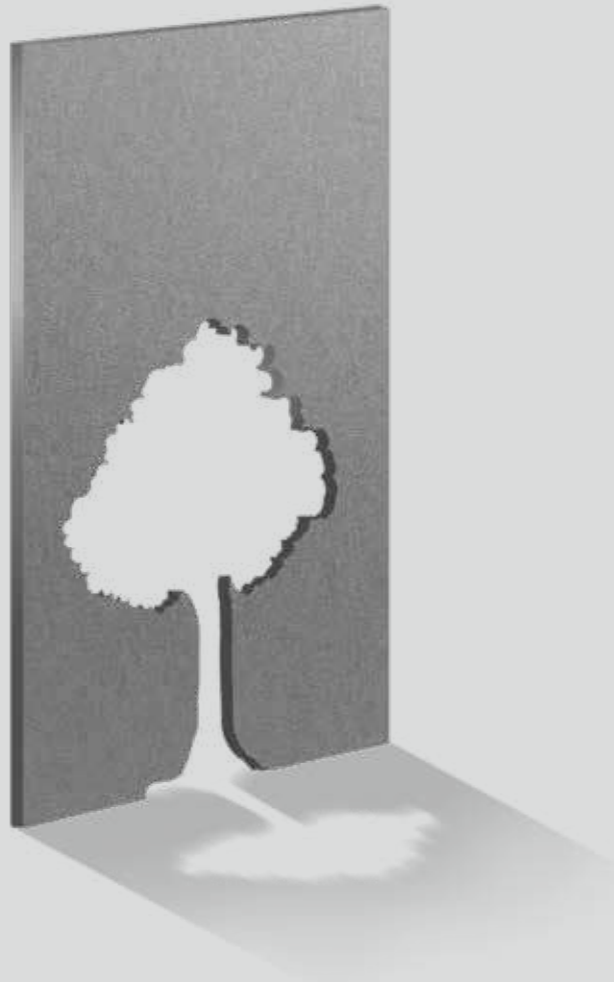

Recycling & VOC Rating

ALUCOBOND® is a 100% recyclable material; both the core and the aluminium skins can be returned to the material cycle and reused.

- The high intrinsic value of aluminium is a major economic incentive for its recycling.
- Aluminium scrap can be repeatedly recycled without lessening its value or diminishing its properties.
- The energy used in recycling is a mere fraction of primary production requirements, often as little as 5%, yielding obvious ecological benefits.

Minimal amounts of VOC's or HAP's are released during the manufacturing process due to strict programs and processes designed to eliminate pollutants.

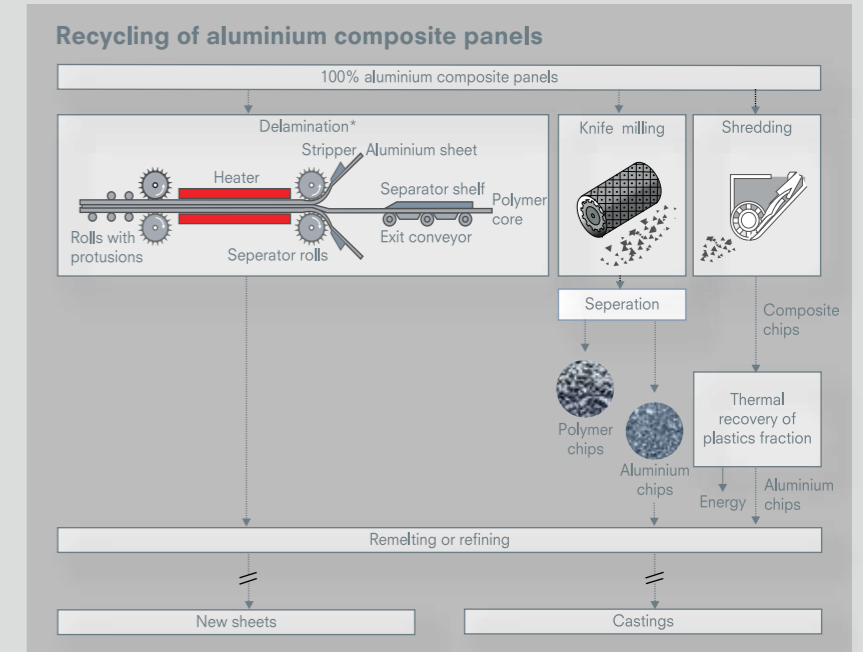

*Drawing based on US patent application 2007/0028432 A1://Ip.com/patapp/US20070028432

LEED Certification

The LEED program has gained much recognition over the past several years and is now the premier sustainability design tool in the building industry.

LEED focuses on constructing buildings that have minimal impact on the environment during construction and occupation and acknowledges that using recycled materials is an essential part of reducing environmental deterioration.

The relatively high percentage of recycled aluminium ensures that ALUCOBOND® can provide a significant contribution to earning LEED points. This recognition is the driving force for using ALUCOBOND® material.

Material	Thickness (mm)	Weight (kg/m ²)	Recycled % Post Consumer	Recycled % Pre-Consumer	LEED Contribution (1.0 x Post + 0.5 x Pre)
ALUCOBOND®	4	7.6	21%	9%	26%
ALUCOLUX®	3	8.1	20%	20%	30%

Recycled content is defined in accordance with the International Organization of Standards document ISO 14021- Environmental labels and declarations-self-declared environmental claims (Type II environmental labelling).

Product	SGBC
ALUCOBOND® A2	✓✓✓
ALUCOBOND® PLUS	✓✓✓
ALUCOBOND® FR	✓✓✓
ALUCOLUX®	✓✓✓
ALUCORE®	✓✓✓



Why Choose ALUCOBOND®



As the inventor of Aluminium Composite Material, ALUCOBOND® has been widely used in the construction industry since its inception in 1969.

ALUCOBOND® is designed and manufactured for the application on facades, roofs, soffits, column claddings and ceilings. It is light, stiff, easy to process and has a high quality coil coated finish. It is the major component of most facades across Asia next to glass.



Durability

ALUCOBOND® uses fluoropolymers (PVDF/FEVE) for surface coating which makes it the preferred choice for longterm architectural use. Inherently, its Marine Grade Alloy is corrosion-resistant and ensures durability in harsh corrosive environment.



Bouquet of Colours & Finishes

ALUCOBOND® offers a wide range of colours, surface finishes and textures to suit every need and meet every requirement.



Fire Safety

ALUCOBOND® PLUS is a fire retardant grade that is suitable for all applications and has a proven safety record, both in testing and real life. Wherever regulations or specifications require it, ALUCOBOND® A2 has set the non-combustible ACM standard since 1992.



Manufacturing Expertise

More than 50 years of experience-driven manufacturing process built over years of research and development.



Warranty

Warranty backed by the leading brand in the industry.



Recyclability

ALUCOBOND® is 100% recyclable material.



Highly Adaptable

ALUCOBOND® is rigid yet highly formable. This opens up wide possibilities for architects and consultants to design their dream projects.



Light Weight

The composite structure of ALUCOBOND® creates an impressive strength-to-weight ratio irrespective of the panel size.



Optimal Flatness

High-speed automated & intelligent ACM production line accurately formulates mineral core content and ensures uniform thickness.



Highly Valued Certification

Class 1A Certification - done through independent 3rd party with inspections and audits on a regular basis.



Savings on Heating / Cooling Costs

The optimally insulated building envelope provides considerable savings in energy costs.



Technical support

For recommendations and the design of appropriate fixing systems, as well as any other assistance you may need, the 3A Composites team is here to support you.

LIGHTNESS MEETS RIGIDITY

ALUCOBOND® has high rigidity when it comes to panels with large sizes. It is a composite sheet made with a core of different degrees of minerals bound between two aluminium sheets.

Thanks to its low weight, ALUCOBOND® is easy to transport and handle during

fabrication and at the site. Its high rigidity and strength makes it the most suitable material for exterior wall cladding. When properly designed and installed, ALUCOBOND® panels will keep their shape and remain flat for years, even when exposed to extreme weather conditions.

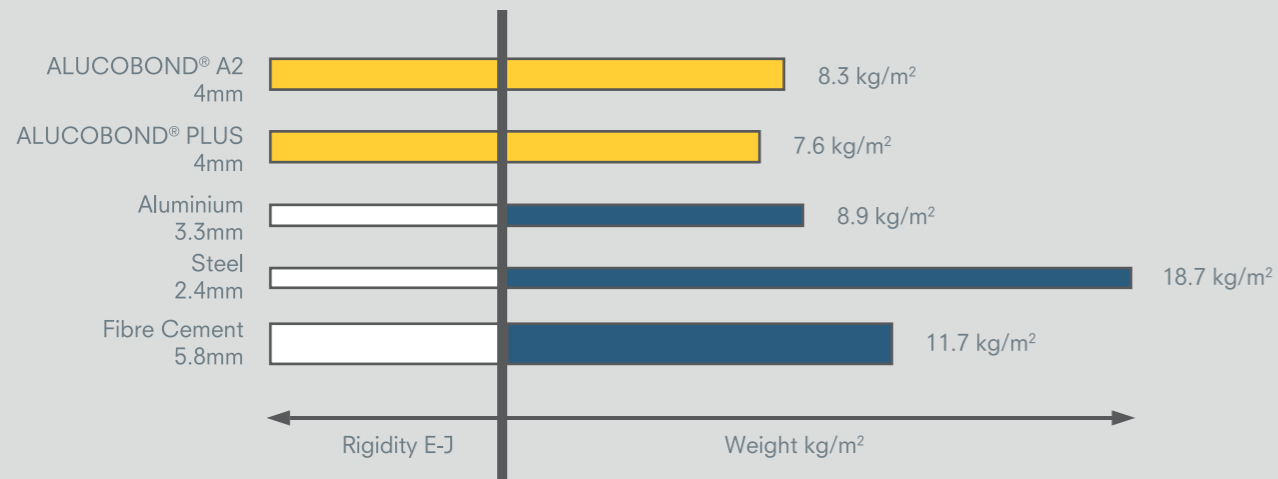

Rigidity (E-J)	Section modulus	ALUCOBOND® PLUS / A2		Aluminium	
		Thickness	Weight	Thickness	Weight
1250 kNcm²/m	1.25 cm³/m	3mm	5.9 kg/m² (PLUS) 6.4 kg/m² (A2)	2.7mm	7.3 kg/m²
2400 kNcm²/m	1.75 cm³/m	4mm	7.6 kg/m² (PLUS) 8.3 kg/m² (A2)	3.3mm	8.9 kg/m²

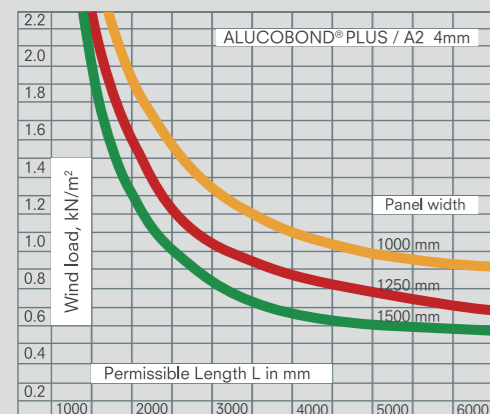

Wind load and permissible panel sizes

The graphs for 4mm thick ALUCOBOND® PLUS / A2 indicate the maximum permissible panel length ($\sigma = 51 \text{ N/mm}^2$) / ($\sigma = 53 \text{ N/mm}^2$) (without having to add a stiffeners) based in applicable design wind load and panel width. Values apply to 4-side supported panels. Values for other systems on request.

SURFACE QUALITY FOR DURABILITY AND COST-EFFECTIVENESS.

UV-RESISTANT COATING

ALUCOBOND® uses 'coil coating' procedure to coat aluminium. This procedure allows the highest quality paint to be applied uniformly.

ALUCOBOND® features fluoropolymer paint systems such as PVDF (Polyvinylidene fluoride) and FEVE (Fluoroethylene Vinyl Ether) which have proven themselves over time.

The assessment of the various paint qualities is undertaken in external weathering tests according to the following parameters:

1. Durability of the coated surface
2. Gloss retention
3. Chalking behaviour

ALUCOBOND® quality benchmarks are far above the usual AAMA (American Architectural Manufacturer's Association) 2605 superior performance specification/E.C.C.A. (European Coil Coating Association) of which 3A Composites is a member.

CLEANING

PVDF/FEVE coating doesn't allow much dirt to accumulate on the surface. Slight soiling can be washed-off using clean water and a neutral cleaning agent. Graffiti can usually be removed by using special cleaning agents.

45° S. Florida

- PVDF
- Vinyl
- Polyester
- Aqueous acrylic
- Solvent acrylic

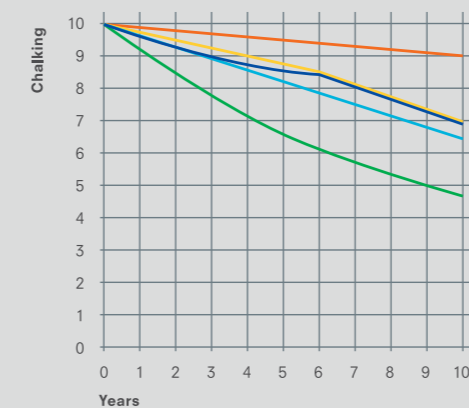
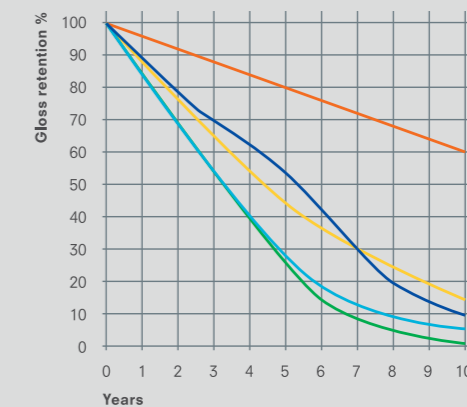
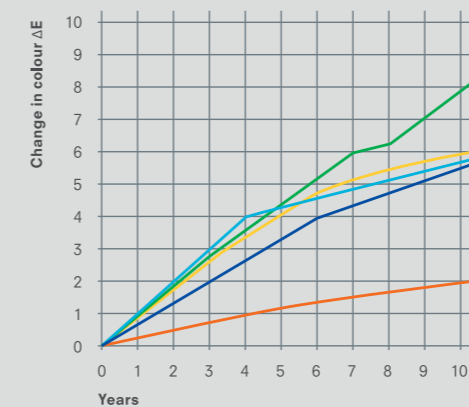

ALUCOBOND® A2

ALUCOBOND® A2 is an aluminium composite panel with a mineral-filled non-combustible core sandwiched between two layers of non-corrosive marine-grade aluminium cover sheets. While the non-combustible core ensures ALUCOBOND® A2 meets the strictest fire regulations and standards, the marine-grade alloy contributes to long-term durability.

With its excellent attributes, ALUCOBOND® A2 is easy to process, highly impact-resistant and weather-resistant, while its non-combustible nature enhances safety.

ALUCOBOND® A2 is ideal for buildings with high human traffic, where both fire safety and aesthetic appeal are paramount. It is widely used in projects such as airports, mass transit systems, stadiums, residential and commercial complexes, shopping malls and hospitals.



ALUCOBOND® A2 | Möbel Martin - Saarbrücken, Germany | Architect: Thomas Müller Ivan Reimann Architekten GmbH | Fabricator: Henke AG
Photography: © Stefan Müller

Fire Classification:
Class A2 - s1, d0
as per EN 13501-1
test standard

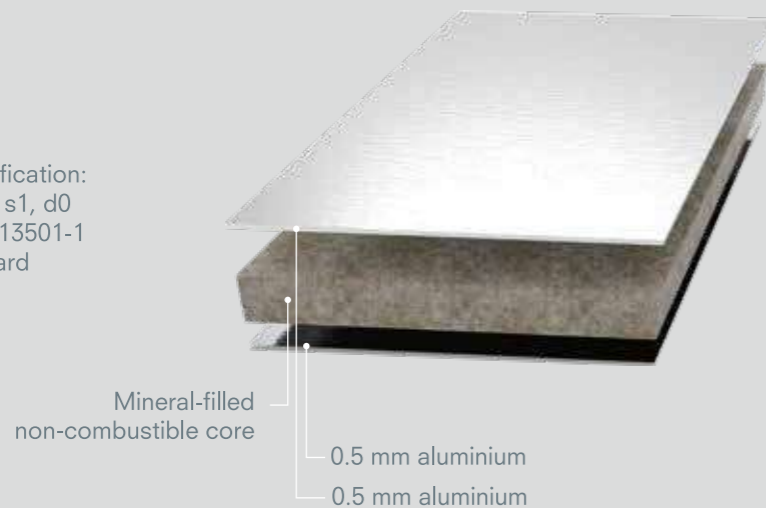

ALUCOBOND® A2 Characteristics:

- Low weight, high rigidity
- Perfect flatness
- Large variety of colours
- Weatherproof
- Vibration-dampening
- Easy to process

Product Range:

- Thickness: 3mm, 4mm
- Width: 1250mm, 1500mm, 1575mm
- Length: 2500mm - 6999mm
- Custom dimensions are available on request

Made to Measure Panels (M2M) and Ready to Install Panels (R2I) service available as a part of value added services (VAS)

Technical Data

PROPERTIES	STANDARDS	UNIT	VALUES
Panel Thickness	Nominal	[mm]	4
Thickness of coated top skin	Nominal	[mm]	0.50
Panel Width	Nominal	[mm]	1250 / 1500
Weight	Nominal	[kg/m ²]	8.3
TECHNICAL PROPERTIES:			
Section Modulus W	ASTM C 393	[cm ³ /m]	1.75
Rigidity (Poisson's ratio $\mu = 0.3$) E-I	ASTM C 393	[kNcm ² /m]	2400
Alloy Grade	ASTM B 209		5005
Temper of Aluminium	ASTM B 209		H24
Modulus of Elasticity	ASTM E8	[N/mm ²]	70,000
Tensile Strength of Aluminium	ASTM E8	[N/mm ²]	$R_m \geq 125$
0.2% Proof Stress	ASTM E8	[N/mm ²]	$R_{p0.2} \geq 90$
Elongation	ASTM E8	[%]	$A_{50} \geq 4$
Linear Thermal Expansion	ASTM D696		2.4 mm / m at 100°C temperature difference
CORE:			
Core			Mineral-filled non-combustible core
SURFACE:			
Lacquering			Coil Coating Fluoropolymer based (PVDF/FEVE)
Gloss (initial value)	ASTM D 523	[%]	As per colour shade
Pencil Hardness	ASTM D 3363		HB - F
ACOUSTICAL PROPERTIES:			
Sound Absorption Factor α_s	ASTM C 423		0.05
Sound Transmission Loss R_w	ASTM E 90	[dB]	27
THERMAL PROPERTIES:			
Thermal Resistance R	ASTM C 1363	[m ² K/W]	0.003
Temperature Resistance		[°C]	-30 to +80
ENVIRONMENT & HEALTH ASPECTS:			
			CFC Free VOC Free
Environment Management System			ISO 14001:2015
Occupational Health and Safety Management System			ISO 45001:2018
Quality Management System			ISO 9001:2015
DIMENSIONAL TOLERANCES:			
Thickness		[mm]	4mm ± 0.2mm
Thickness of coated top skin		[mm]	0.5 ± 0.05mm
Weight		[kg/m ²]	8.3 ± 5%
Width		[mm]	Upto 1500mm + 4mm
Length		[mm]	< 4000mm + 6mm Above 4000mm +10mm

*Specifications are subject to change without prior notice / intimation.

ALUCOBOND® A2 | BCF Arena - Fribourg, Switzerland
Architect: Bfik Architectes | Fabricator: Werkstätte Liechtblick
Photography: © Allega GmbH



ALUCOBOND® PLUS

ALUCOBOND® PLUS is a high-performance fire retardant aluminium composite panel with two aluminium coversheets of non-corrosive marine grade alloy with mineral-filled fire retardant core.

Just like all other variants of ALUCOBOND®, these panels are flat, rigid, and highly formable, making them easy to fabricate with standard processing tools.

These features are particularly valued by architects, as they enhance the panel's adaptability and aesthetic appeal in a wide range of architectural projects.

With myriad applications, ALUCOBOND® PLUS is used extensively for airports, mass transit systems, stadiums, residential and commercial complexes, shopping malls and hospitals.



ALUCOBOND® PLUS | Jewel Changi Airport - Dome, Singapore | Architect: Safdie Architects; RSP Architects
Fabricator/Installer: Mero Asia Pacific Pte Ltd | Photography: Shutterstock

Fire Classification:
Class B - s1, d0 as per
EN 13501-1 test standard

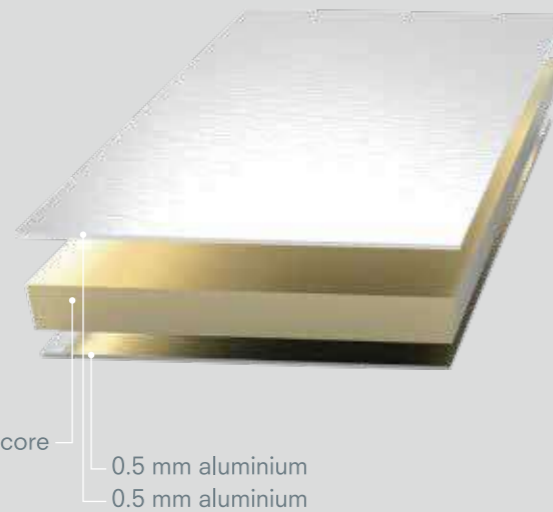

Mineral-filled fire retardant core

0.5 mm aluminium
0.5 mm aluminium

ALUCOBOND® PLUS Characteristics:

- Fire retardant
- Low weight, high rigidity
- Perfect flatness
- Large variety of colours
- Weatherproof
- Vibration-dampening
- Easy to process

Product Range:

- Thickness: 3mm, 4mm
- Width: 1000mm, 1250mm, 1500mm, 1575mm
- Length: 2500mm - 6999mm
- Custom dimensions are available on request

Made to Measure Panels (M2M) and Ready to Install Panels (R2I) service available as a part of value added services (VAS)

Technical Data

PROPERTIES	STANDARDS	UNIT	VALUES
Panel Thickness	Nominal	[mm]	4
Thickness of coated top skin	Nominal	[mm]	0.50
Panel Width	Nominal	[mm]	1250 / 1500
Weight	Nominal	[kg/m ²]	7.6
TECHNICAL PROPERTIES:			
Section Modulus W	ASTM C 393	[cm ³ /m]	1.75
Rigidity (Poisson's ratio $\mu = 0,3$) E-I	ASTM C 393	[kNcm ² /m]	2400
Alloy Grade	ASTM B 209-04		5005
Temper of Aluminium	ASTM B 209-04		H24
Modulus of Elasticity	ASTM E8	[N/mm ²]	70,000
Tensile Strength of Aluminium	ASTM E8	[N/mm ²]	$R_m \geq 125$
0.2% Proof Stress	ASTM E8	[N/mm ²]	$R_{p0.2} \geq 90$
Elongation	ASTM E8	[%]	$A_{50} \geq 4$
Linear Thermal Expansion	ASTM D696		2.4 mm / m at 100°C temperature difference
CORE:			
Core			Mineral-filled fire retardant core
SURFACE:			
Lacquering			Coil Coating Fluoropolymer based (PVDF/FEVE)
Gloss (initial value)	ASTM D 523	[%]	As per colour shade
Pencil Hardness	ASTM D 3363		HB - F
ACOUSTICAL PROPERTIES:			
Sound Absorption Factor α_s	ASTM C 423		0.05
Sound Transmission R_w	ASTM E 90	[dB]	STC: 30
THERMAL PROPERTIES:			
Thermal Resistance R	ASTM C 1363	[m ² K/W]	0.009
Temperature Range		[°C]	-30 to +80
ENVIRONMENT & HEALTH ASPECTS:			
			CFC Free VOC Free
Environment Management System			ISO 14001:2015
Occupational Health and Safety Management System			ISO 45001:2018
Quality Management System			ISO 9001:2015
DIMENSIONAL TOLERANCES:			
Panel Thickness		[mm]	4mm ± 0.2mm
Thickness of coated top skin		[mm]	0.50 ± 0.05mm
Weight		[kg/m ²]	7.5 ± 5%
Width		[mm]	Upto 1500mm + 4mm
Length		[mm]	< 4000mm + 6mm Above 4000mm +10mm

*Specifications are subject to change without prior notice / intimation.

ALUCOBOND® PLUS I House of Music - Budapest, Hungary
Architect: Sou Fujimoto Architects | Fabricator: Magyar Építő Zrt.
Photography: György Palkó





Fire Classification

ALUCOBOND® PLUS

COUNTRY	TEST ACCORD. TO ...	CLASSIFICATION
Australia	AS ISO 9705 AS 1530.3 EN 13501-1	Group 1 material SMOGR A 1.385 m ² / s ² 0 (ignitibility) 0 (flame spread) 0 (heat evolved) 0-1 (smoke development) B-s1, d0
China	GB 8624-2012	Class B1 (B-s1,d0, t0)
India	EN 13501-1 ASTM E84	Class B-s1,d0 Class A
EU	EN 13501-1	Class B-s1, d0
Germany	EN 1187 (method 1) / DIN 4102-7	Passed
Great Britain England / Wales / Scotland	BS 476, Part 6 & 7 BR 135 BS 8414 part 1 & 2 BS EN 13501-1	Class 0 met the performance criteria Passed Class B-s1, d0
Malaysia	BS 8414-1 BS 476, Part 6 BS 476, Part 7	Passed Class 0 Class 1
Poland	PN-90/B-02867	NRO
Russia	GOST 30244-94 GOST 30402-95 GOST 12.1.044-89 GOST 12.1.044-89	G1 (combustibility) W1 (flammability) D1 (smoke development) T1 (toxicity)
Singapore	BS 476, Part 6&7 Approved for Interior cladding Roofing, Ceiling applications	Passed
Switzerland	VKF	RF2
UAE	NFPA 285 EN 13501-1 ASTM E84 (Core Exposed)	Passed Class B-s1, d0 Class A
USA	ASTM E84 (Core Exposed) NFPA 285	Class A Passed

ALUCOBOND® A2

COUNTRY	TEST ACCORD. TO ...	CLASSIFICATION
Australia	AS ISO 9705 AS 1530.3 Indices EN 13501-1	Group 1 material SMOGR A 0.630 m ² / s ² 0 (ignitibility) 0 (flame spread) 0 (heat evolved) 0-1 (smoke development) A2-s1, d0
China	GB 8624-2012	Class A (A2- s1,d0, t0)
India	EN 13501-1 ASTM E84	Class A2-s1,d0 Class A
EU	EN 13501-1	Class A2-s1, d0
Great Britain England / Wales / Scotland	BR 135 BS 8414 part 1 & 2 BS EN 13501-1	met the performance criteria Passed Class A2-s1,d0 (panel core)
Malaysia	BS 8414-1 BS 476, Part 6 BS 476, Part 7	Passed Class 0 Class 1
Poland	EN 13501-1	Class A2-s1, d0
Russia	GOST 30244-94 GOST 30402-95 GOST 12.1.044-89 GOST 12.1.044-89	G1 (combustibility) W1 (flammability) D1 (smoke development) T1 (toxicity)
Singapore	BS 476, Part 6&7 (Core Exposed)	Passed
Switzerland	VKF	RF1
UAE	BS 8414-2 NFPA 285 EN 13501-1 ASTM E84 (Core Exposed)	Passed Passed Class A2-s1, d0 Class A

ALUCOBOND® PLUS I Starry Sky Art Museum - Kunming, China
Architect: Maps design | Fabricator: Yunnan Wanhe Construction Engineering Co. Ltd.
Photography: Mark Shen



ALUCOBOND® FR

ALUCOBOND® FR is an aluminium composite panel that provides a balanced solution of safety, durability, and affordability, particularly suited for architectural projects where managing costs is a key consideration. Comprising of two aluminium cover sheets with a mineral-filled fire retardant core, ALUCOBOND® FR is designed to offer essential fire protection without compromising on key features.

ALUCOBOND® FR has properties such as surface flatness, formability, resistance to weather and simple processing.

ALUCOBOND® FR can be used for commercial buildings, residential apartments, office buildings, etc.



ALUCOBOND® FR | Weikfield IT Park - Pune, India | Fabricator/Installer: Metro Glass | Photography: 3A Composites India Pvt. Ltd.

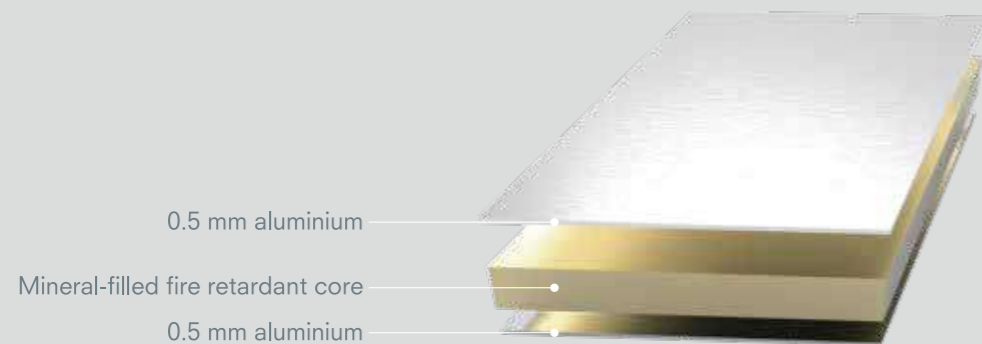

Fire Classification:
Class B - s1,d0 as per
EN 13501-1 test standard

ALUCOBOND® FR Characteristics:

- Fire retardant
- Low weight, high rigidity
- Perfect flatness
- Large variety of colours
- Vibration-dampening
- Easy to process

Product Range:

- Thickness: 3mm, 4mm
- Width: 1000mm, 1250mm, 1500mm, 1575mm
- Length: 2500mm - 6999mm
- Custom dimensions are available on request

Made to Measure Panels (M2M) and Ready to Install Panels (R2I) service available as a part of Value Added Services (VAS)

Technical Data

PROPERTIES	STANDARDS	UNIT	VALUES
Panel Thickness	Nominal	[mm]	4
Skin Thickness	Nominal	[mm]	0.50
Weight	Nominal	[kg/m ²]	7.6
TECHNICAL PARAMETERS:			
Section Modulus W	ASTM C 393	[cm ³ /m]	1.75
Rigidity (Poisson's ratio $\mu = 0,3$) E-I	ASTM C 393	[kNcm ² /m]	2400
Alloy Grade	ASTM B 209-04		3003/3105
Temper of Aluminium	ASTM B 209-04		H24
Modulus of Elasticity	ASTM E8	[N/mm ²]	70,000
Tensile Strength of Aluminium	ASTM E8	[N/mm ²]	R _m ≥ 125
0.2% Proof Stress	ASTM E8	[N/mm ²]	R _{p0.2} ≥ 90
Elongation	ASTM E8	[%]	A ₅₀ ≥ 4
Linear Thermal Expansion	ASTM D696		2.4 mm/m at 100°C temperature difference
CORE:			
Core			Mineral-filled fire retardant core
SURFACE:			
Surface			Coil Coating
Lacquering			Fluoropolymer based (PVDF/FEVE)
Gloss (initial value)	ASTM D 523	[%]	As per colour shade
Pencil Hardness	ASTM D 3363		HB - F
ACOUSTICAL PROPERTIES:			
Sound Absorption Factor α_s	ASTM C 423		0.05
Sound Transmission R _w	ASTM E 90	[dB]	STC: 30
THERMAL PROPERTIES:			
Thermal Resistance R	ASTM C 1363	[m ² K/W]	0.003
Temperature Range		[°C]	-30 to +80
FIRE PROPERTIES :			
Fire Classification	EN 13501-1		Class B - s1, d0
ENVIRONMENT & HEALTH ASPECTS:			
			CFC Free VOC Free
Environment Management System			ISO 14001:2015
Occupational Health and Safety Management System			ISO 45001:2018
Quality Management System			ISO 9001:2015
DIMENSIONAL TOLERANCES:			
Panel Thickness		[mm]	4mm ± 0.2mm
Skin Thickness		[mm]	0.50 ± 0.05mm
Weight		[kg/m ²]	7.5 ± 5%
Width		[mm]	Upto 1500mm + 4mm
Length		[mm]	< 4000mm + 6mm Above 4000mm +10mm

*Specifications are subject to change without prior notice / intimation.

ALUCOBOND® FR I Candor - Noida, India
Architect: RSP Design Consultants (India) Pvt. Ltd. | Fabricator: KSV Infra
Photography: 3A Composites India Pvt. Ltd.



ALUCORE® HONEYCOMB

ALUCORE® HONEYCOMB is a unique panel with an aluminium honeycomb core embedded between two aluminium skins. The product is a true representation of an advanced sandwich composite. The ultra-low weight of a core and the increased distance between the cover sheets increases rigidity while keeping the panel weight extremely low. The result is unmatched strength-to-weight ratio.

ALUCORE® HONEYCOMB therefore, has a definite advantage when it comes to

projects with high demands on material stiffness - such as facade cladding or roofing where it is exposed to extremely high wind loads, or for large self-supporting and even walkable roofs.

ALUCORE® HONEYCOMB can be used for a wide variety of applications from the transport industry to architecture and has fantastic properties such as extraordinary flatness, large variety of colours, and high formability.



ALUCORE® I Carrefour Shopping Centre - Krakow, Poland | Architect: Lipski, Gilewicz, Lisowski; L.G. Asymetria Sp. Z o.o., Krakau
Fabricator: Alustar Sp. Z o.o., Krakau

Fire Classification:
Class A2 - s1, d0
as per EN 13501-1
test standard

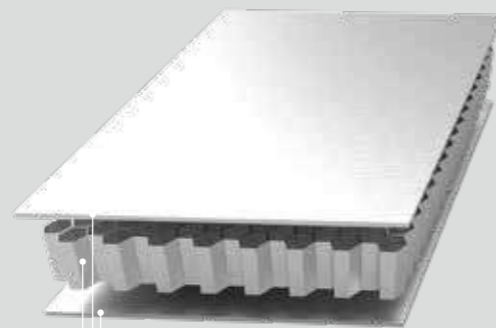

Aluminium honeycomb core — 0.5mm/1mm
1 mm aluminium

ALUCORE® HONEYCOMB Characteristics:

- Extreme strength-to-weight ratio
- Perfect flatness, low weight and extremely high rigidity
- High formability allows design freedom
- Vibration damping (no additional sound damping needed)
- Simple processing using conventional tools (e.g. for folding and bending)
- Excellent weather resistance
- Large panel sizes possible due to high rigidity
- Larger panel sizes mean less substructure, lowering cost

Product Range:

- Thickness: 10mm, 15mm, 20mm, 25mm
- Width: 1250mm, 1500mm
- Length: 2500mm - 6999mm

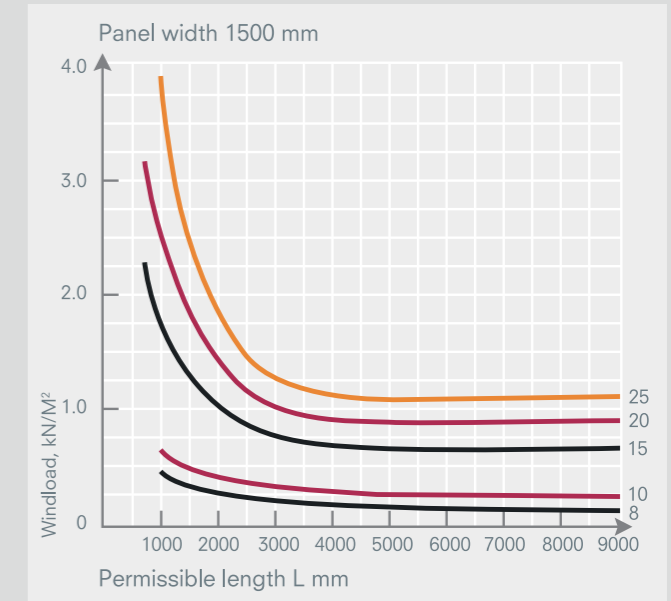
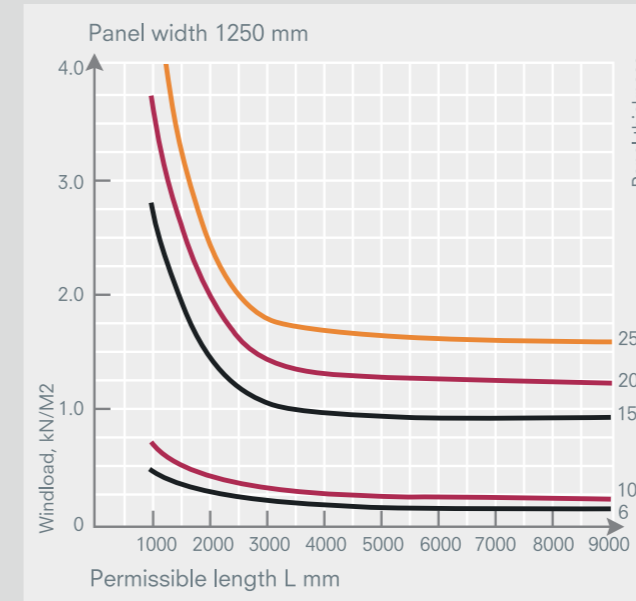

Wind load and permissible panel sizes

The diagrams indicate the available range of panel thickness and permissible range lengths at a given panel width (1250 or 1500mm), depending on the loads applied. The diagrams apply to panels supported on four sides (corners fixed). Dimensional values for other systems are available on request.



Rigidity compared with thickness and weight

The graph indicates that 25mm ALUCORE® has the same rigidity (22000 kN) as of 15.2mm solid aluminium sheet, but only weighs 5kg Vs 40kg of solid aluminium.

Technical Data

THICKNESS	UNIT	10mm	15mm	20mm	25mm
Front Sheet	[mm]	1.0			
Back Sheet	[mm]	0.5	1.0	1.0	1.0
Weight	[kg/m ²]	5.0	6.7	7.0	7.3

TECHNICAL PROPERTIES	STANDARDS	UNIT	10mm	15mm	20mm	25mm
Section modulus	W	[cm ³ /m]	4.6	14	19	24
Rigidity E-J		[kNm ² /m]	21.900	75.500	138.900	221.600
Alloy of Aluminium Sheets	ASTM B209-04		EN AW - 3XXX / 5XXX			
Temper of Aluminium Sheets	ASTM B209-04		H22 / H24 / H42			
Modulus of Elasticity	ASTM E8	[N/mm ²]	70000			
Tensile Strength of Aluminium		[N/mm ²]	R _m ≥ 120 - 185			
0.2 % Proof Stress		[N/mm ²]	R _{p0.2} ≥ 80			
Elongation		[%]	A50 ≥ 5			
Linear Thermal Expansion			2.4 mm/m (at 100°C temperature difference)			

SURFACE	STANDARDS	UNIT	10mm	15mm	20mm	25mm
Coating			PVDF / FEVE / HDP / Mill Finish			
Gloss Levels	ASTM D523	[%]	25-80			
Pencil Hardness	ECCA - T4		HB-F			

ACOUSTICAL PROPERTIES	STANDARDS	UNIT	10mm	15mm	20mm	25mm
Sound Absorption Factor α _s	ISO 354		0.05 - 0.07			
Airborne sound insulation index (acc. to ISO 717-1, ISO 140-3)	ISO 717	dB	21 - 25			

THERMAL PROPERTIES	STANDARDS	UNIT	10mm	15mm	20mm	25mm
Thermal conductivity (regarding total thickness, incl. cover sheets)		[W/mK]	1.35	1.80	2.25	2.70
Thermal Resistance		[m ² K/W]	0.0074	0.0084	0.0089	0.0093
Temperature Resistance		[°C]	-40 to +80			

Fire Classification

COUNTRY	TEST ACCORD. TO..	CLASSIFICATION
Singapore	BS 476 Part 4	Approved for outdoor and indoor wall cladding for any type of building without limit as to their height
EU	EN 13501-1 EN 13501-1	Class B, s1, d0 (standard) Class A2, s1, d0 (on request)

*Specifications are subject to change without prior notice/intimation.

ALUCORE® | Espace culturel Jacobin - Le Mans, France
Architect : BABIN & RENAUD | Fabricator: TIM PLEXIAL
Photography: © Thibault Savary



ALUCORE® | Repsol Headquarters - Madrid, Spain
Architect: Rafael de La-Hoz Arquitectos | Fabricator: Folcrá & Estrumajer
Photography: © Alfonso Quiroga Ferro

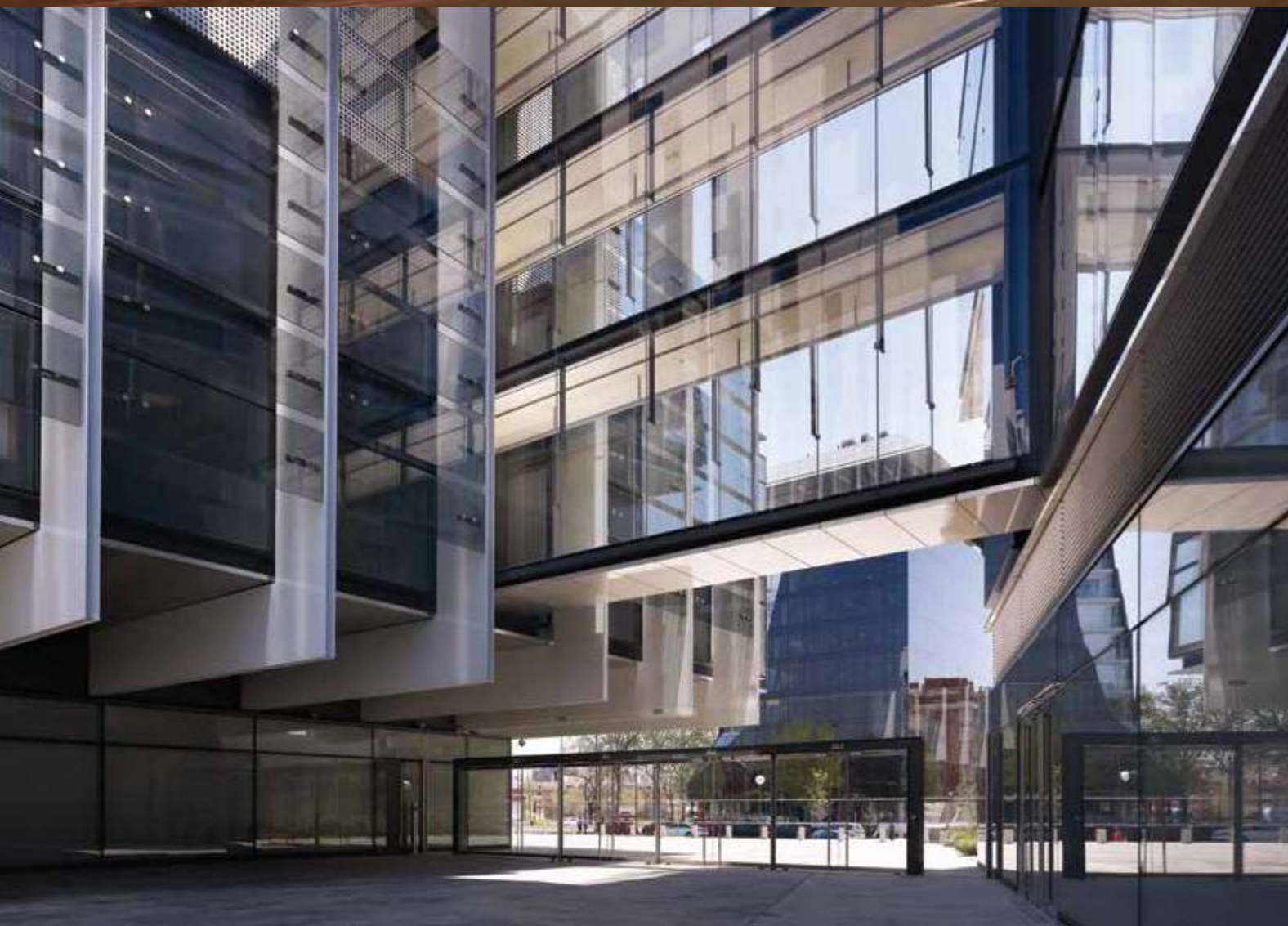

ALUCORE® ACCP

ALUCORE® ACCP is a light weight cladding material with a corrugated aluminium core sandwiched between two aluminium skins making it highly rigid. Devoid of any thermoplastic core, it is perfectly suitable for projects with stringent fire regulations.

ALUCORE® ACCP offers unmatched flatness enhancing the beauty of buildings.

The panels are easily formable using common processing methods giving architects flexibility to execute complex designs.

ALUCORE® ACCP can be used for facades, ceilings, soffits and interior wall cladding at airports, mass transit systems, IT parks, commercial complexes, stadiums, community halls, education institutes, hotels, hospitals and residential complexes.

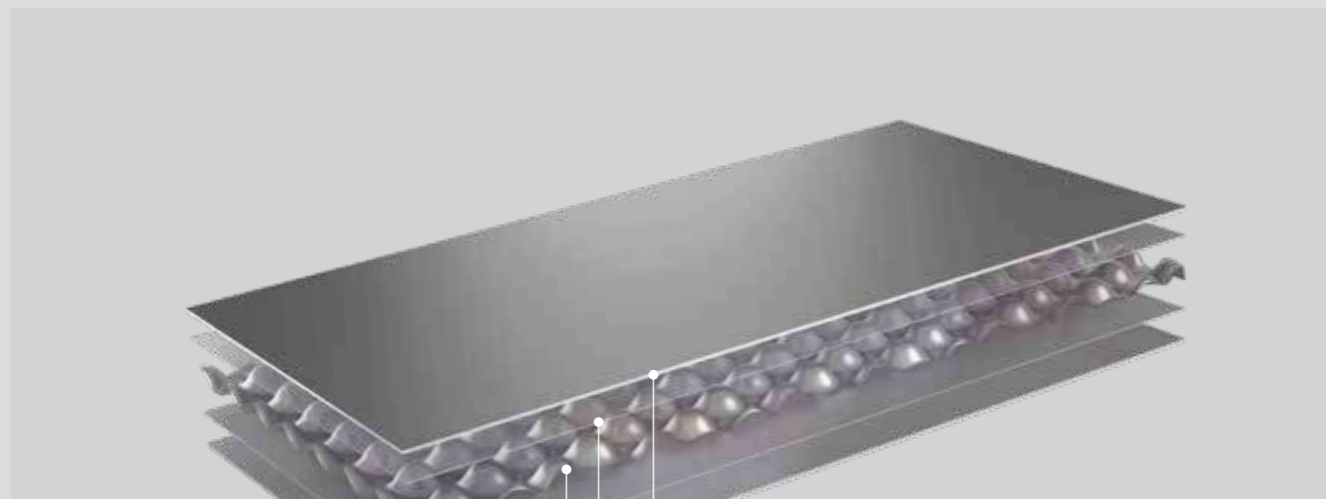

Fire Classification:
Class A2 - s1, d0
as per EN 13501-1
test standard

- 0.7mm Aluminium Top Skin
- Adhesive
- Aluminium Corrugated Core
- Adhesive
- 0.5mm Aluminium Bottom Skin

ALUCORE® ACCP Characteristics:

- Perfect flatness, low weight and high rigidity
- Simple processing using conventional tools (e.g. for folding and bending)
- Excellent weather resistance
- Large size panels possible resulting in low cost for substructures and fasteners
- Highly formable

Product Range:

- Panel Thickness: 4mm and 6mm
- Width: 1250mm, 1500mm
- Length: ≤6000mm

Technical Data

PROPERTIES	STANDARDS	UNIT	VALUES
Panel Standard Thickness	Nominal	[mm]	4 / 6
Coated Skin Thickness, Front Side	Nominal	[mm]	0.7
Coated Skin Thickness, Rear Side	Nominal	[mm]	0.5
Weight	Nominal	[kg/m ²]	4.45
TECHNICAL PROPERTIES:			
Rigidity		[kNcm ² /m	2600 / 6500
Alloy Of Cover Sheets	ASTM B209-04		5005
Temper of Cover Sheets	ASTM B209-04		H24
Modulus of Elasticity	ASTM E8	[N/mm ²]	70,000
Tensile Strength of Aluminium	ASTM E8	[N/mm ²]	R _m ≥ 125
0.2% Proof Stress	ASTM E8	[N/mm ²]	R _{p0.2} ≥ 90
Elongation	ASTM E8	[%]	A ₅₀ ≥ 4
SURFACE:			
Lacquering			Coil Coating Fluoropolymer based (PVDF/FEVE)
Gloss (Initial Value)	ASTM D523		As per the colour shade
Pencil Hardness	ASTM D3363		HB ~ F
THERMAL PROPERTIES:			
Temperature Range		[°C]	-40 to +80
FIRE PROPERTIES:			
Fire Classification	EN 13501-1		Class A2 - s1, d0
ENVIRONMENT & HEALTH ASPECTS:			
Environment Management System			ISO 14001 : 2015
Occupational Health & Safety Management System			ISO 45001 : 2018
Quality Management System			ISO 9001 : 2015
DIMENSIONAL TOLERANCES:			
Panel Thickness		[mm]	± 0.2mm
Thickness of Coated Skins		[mm]	± 0.05mm
Weight		[kg/m ²]	± 5%
Width		[mm]	Upto 1250mm + 2mm
Length		[mm]	< 4000mm + 6mm Above 4000mm + 10mm

*Specifications are subject to change without prior notice/intimation.

Fire Classification

COUNTRY	TEST ACCORD. TO ...	CLASSIFICATION
India	EN 13501-1	Class A2 - s1, d0
Australia / New Zealand	AS/NZS 1530.3	Passed 0 (Ignitability index) 0 (Spread of flame index) 0 (Heat evolved index) 0-1 (Smoke developed index)
	AS/NZS 3837	Group 1 as per AS 5637.1
	AS/NZS 1530.1	Passed

ALUCORE® CLAD

ALUCORE® CLAD is a value-added cladding system solution from ALUCOBOND®. It is made of honeycomb panel prefabricated with aluminium extrusions - Ready to Install.

ALUCORE® CLAD can be used for applications such as facade cladding, roofing, ceiling, soffit and shelters. This makes ALUCORE® CLAD an ideal choice for projects ranging from airports to metros, commercial complexes to residential buildings, stadiums to community buildings and hotels to hospitals.

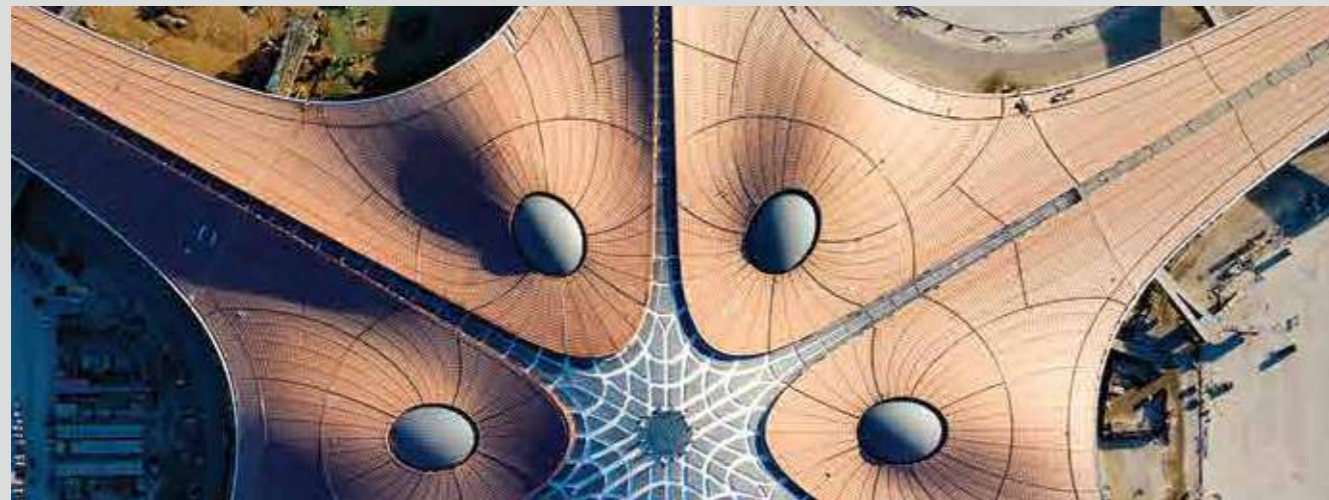

ALUCORE® CLAD | Daxing (Beijing) Airport - Beijing, China | Architect: Zaha Hadid Architects & ADP Ingenierie | Fabricator: Beijing Construction Engineering Group
Photography: Zhaoqi Li

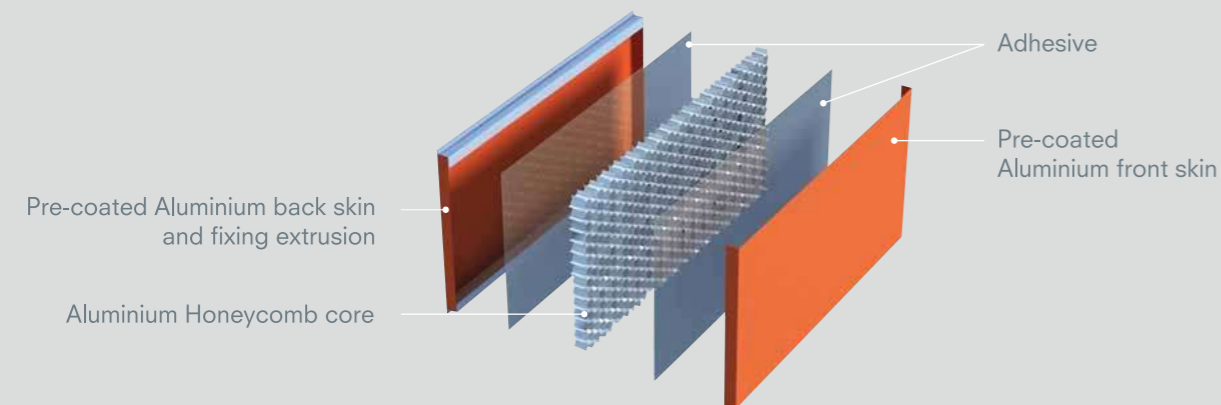

ALUCORE® CLAD Characteristics:

- Customised solution. Ready to install panels (R2I)
- Best available industrial coating and lamination technology
- Stronger installation - Panel perimeter fixing anchors additionally secures the overall panel assembly
- Pre-fixed extrusions (horizontal/vertical orientation) Hence easy and quick installation
- ALUCORE® CLAD fixing system allows quick replacement eliminating the need to take-out all the panels

Product Range:

- Thickness: 10mm, 15mm, 20mm, 25mm
- Width: 1250mm, 1500mm
- Length: >3000mm

Technical Data

TECHNICAL ITEM	STANDARDS	UNIT	Standard T12mm*	Standard T25mm*
SURFACE				
Front Cover Sheet**		[mm]	0.7 ~ 1.0	
Weight		[kg/m ²]	5.5	6
Alloy	EN 573-3		AA5005A (ALMg1), H42 AA3003, H44	
Coil Coating System	Coil Coating		PVDF/HDP/POLY	
Gloss (Initial Value)	ECCA T2	[%]	30 ~ 45	
Pencil Hardness	ECCA T4		HB ~ F	
CORE				
Cell Size		[mm]	6.3 ~ 19	
Density		[kg/mm ³]	> 50	
Thickness of Al Foil		[mm]	0.076	
Bare Compressive Strength		[N/mm ²]	≥ 0.8	
MECHANICAL PROPERTIES				
Modulus of Elasticity	EN 1999 1-1	[N/mm ²]	70,000	
Tensile Strength Cover Sheets	EN 485-2	[N/mm ²]	R _m ≥ 125	
0.2% Proof Stress	EN 485-2	[N/mm ²]	R _{p0.2} ≥ 80	
Elongation		[%]	A50 ≥ 3	
Linear Thermal Expansion	EN 1999 1-1		2.4mm/m (at 100°C temperature difference)	
ACOUSTICAL PROPERTIES				
Sound Absorption Factor α _s	ISO 345		0.05	
Sound Insulation R _w	ISO 717-1 EN ISO 6721	[dB]	15	25
THERMAL PROPERTIES				
Thermal Conductivity λ***	DIN 52612	[W/mK]	1.35	2.7
Thermal Resistance R	DIN 52612	[m ² K/W]	0.0047	0.0093
Heat Transition Coefficient U	DIN 4108	[W/m ² K]	5.65	5.58
Surface Fire Performance	BS1991ADB		Class 0	

Specifications are subject to change without prior notice/intimation.

Remark:

*Based on the specific application, there are kinds of thickness, such as 10mm, 15mm, 20mm etc.

**There are also 0.5mm or 0.7mm top skin available for specific applications

***Refers to total thickness, including aluminium skins

ALUCORE® CLAD | Daxing (Beijing) Airport - Beijing, China
Architect: Zaha Hadid Architects & ADP Ingenierie | Fabricator: Beijing Construction Engineering Group
Photography: Zhaoqi Li



ALUCOLUX®

Designed for architectural applications, ALUCOLUX® features multi-coat, multi-bake process on a continuous industrial grade coil coating line using the highest grade of PVDF/FEVE paint system. This process not only ensures colour consistency and long-term durability but also renders it non-combustible.

Along with solids, metallics and specialty finishes embossed patterns resembling wood

and stone are also possible with ALUCOLUX®. With good formability, the panels can be shaped into complex designs using standard processing methods, offering architects and designers the flexibility to achieve their creative visions. As a result, these panels are used in a wide range of projects worldwide, including airports, mass transit systems, commercial and residential complexes, stadiums, malls, hotels, and hospitals.



ALUCOLUX® | Telepark - Singapore, Singapore | Architect: Façade Consultant - Arup Singapore, Architect - Chansez Pte. Ltd. Fabricator: Evergreen Engineering & Construction Pte. Ltd. | Photography: Visual Verve Studios

Fire Classification:
Non-combustible
Class A1 - s0, d0 according to
EN 13501-1 test standard



2mm/3mm thick solid aluminium sheet

ALUCOLUX® Characteristics:

- All ALUCOBOND® surface finishes and colours are possible with ALUCOLUX®
- Coating process conforming to AAMA 2605 for superior performance specification and ECCA guidelines
- Embossed stone and wood look available
- Architectural grade alloy & temper for perfect flatness and performance
- Easy to process
- 15 years warranty

Product Range:

- Thickness: 2mm or 3mm
- Width: 1000mm, 1250mm, 1500mm
- Length: ≤ 6000 mm

Made to Measure Panels (M2M) and Ready to install Panels (R2I) service available as a part of value added services (VAS)

Technical Data

TECHNICAL PROPERTIES	STANDARDS	COIL-COATED
Alloy	EN 573-3	3003
Temper	EN 515	H24
Standard Thickness*	EN 485-4	3mm
Standard Widths**	EN 485-4	1000mm, 1250mm, 1500mm, 1575mm
Standard Length	EN 485-4	≤ 6000 mm
Panel Weight		8.1 Kg/m ²
Tensile Strength	EN 485-2	145-185Mpa
Modulus of Elasticity	EN 485-5	70,000 N/mm ²
Yield Strength Rp0.2	EN 485-2	≥ 115 Mpa
Elongation	EN 485-2	A ₅₀ $\geq 6\%$
Linear Expansion	EN 1999 1-1	2.4mm/m at 100°C temperature difference
Surface		PVDF/FEVE
Gloss	EN 13523-2	25-40%
Coating Thickness ***		28-45 microns

Specifications are subject to change without prior notice/intimation.

Remark:

*Other thicknesses available on request.

**Custom widths available on request.

*** Coating thicknesses varies for different surface finishes.

Fire Classification

COUNTRY	TEST ACCORD. TO ...	CLASSIFICATION
China	EN 13501-1	A1-s0, d0
Australia	AS 13501.1	PASSED
New Zealand	BS 8414-1	PASSED
Australia	AS 3837	Group 1 as per AS 5637.1
Australia	AS 1530.3	PASSED 0 (ignitibility) 0 (flame spread) 0 (heat evolved) 2 (smoke development)

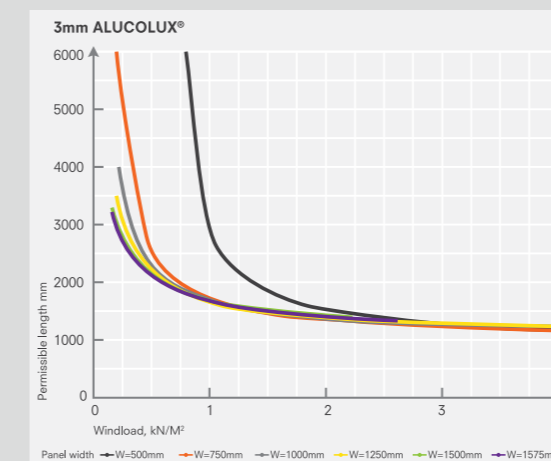

Wind load and permissible panel sizes

The diagram indicates the available range of panel sizes and permissible range lengths at a given panel width, depending on the wind load applied.

The diagram apply to panels supported on four sides (corners fixed). Dimensional values for other systems are available on request.

ALUCOLUX® | Timberly Road – Auckland, New Zealand
Architect: Eclipse Architecture | Fabricator: Symonite
Photography: © Mark Scowen



ALUCODUAL®

ALUCODUAL® is a pre-coated, engineered solid sheet consisting of 2/3 layers of laminated aluminium skins, designed to ensure flatness, which can be difficult to achieve with standard post-coated solid sheets.

Compared to a single sheet of aluminium of the same thickness, ALUCODUAL® offers increased stiffness and rigidity, allowing for the use of larger cassettes and panels, reducing the number of joints and helping to manage overall costs.

The panels undergo a multi-coat, multi-bake process on an industrial-grade continuous coil coating line, using a fluorocarbon-based PVDF/FEVE paint system. This ensures long-term durability and performance.

A key feature of ALUCODUAL® is its fire retardant property. Without a thermoplastic core, the material remains inactive in case of fire, emitting no toxic gases or burning droplets.

ALUCODUAL® is commonly used for facades, wall cladding, soffits, column cladding and decorative ceilings & interior walls at airports and other mass transit systems, commercial and residential complexes, stadiums, malls, hotels and hospitals.

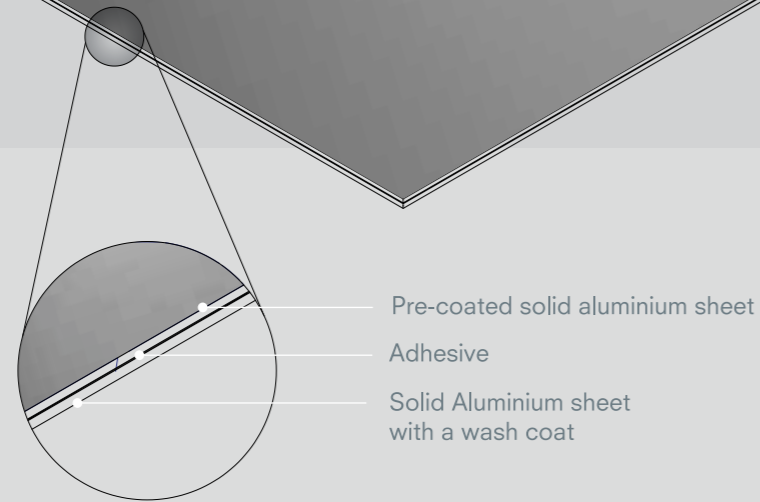
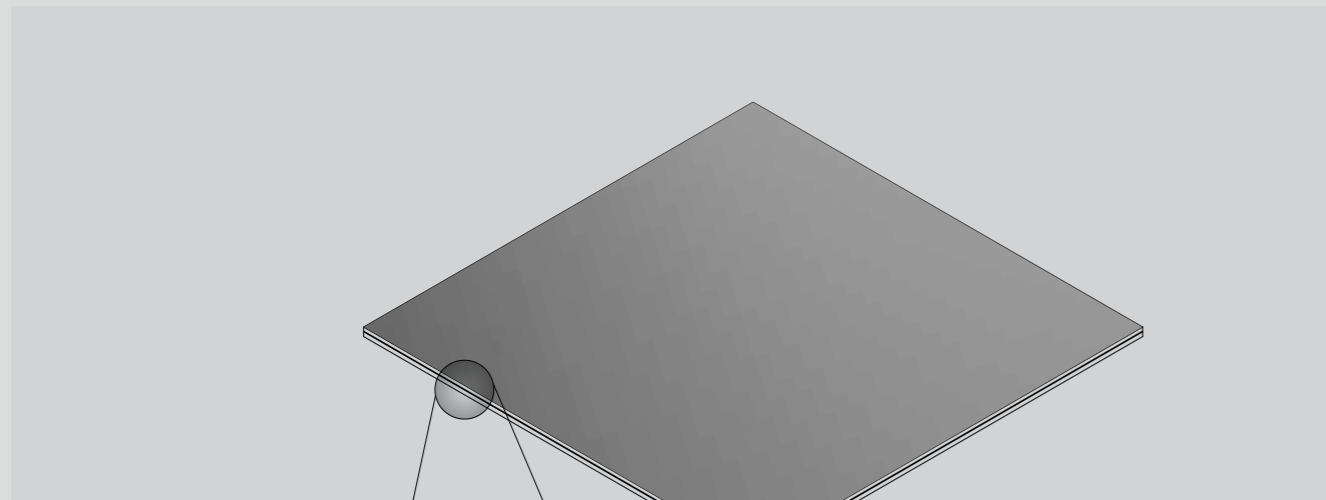

Fire Classification:
Class A2 - s1, d0
as per EN 13501-1
test standard

- Pre-coated solid aluminium sheet
- Adhesive
- Solid Aluminium sheet with a wash coat

ALUCODUAL® Characteristics:

- Engineered for Perfect Flatness
- Enhanced stiffness and rigidity
- Corrosion resistant 5005 marine grade alloy
- Coated with high-grade PVDF/FEVE paint system as per AAMA 2605 for superior performance specification
- Larger panel sizes allowing bigger cassettes
- Fire retardant
- Easy to process
- 10 years warranty

Product Range:

- Thickness:
ALUCODUAL® - 2mm and 2.5mm
ALUCODUAL® PLUS - 3mm
- Width: 1250mm, 1500mm
- Length: $\leq 6000\text{mm}$

Technical Data

PROPERTIES	STANDARDS	UNIT	VALUES
Panel Standard Thickness	Nominal	[mm]	2 / 2.5 / 3
Panel Standard Width	Nominal	[mm]	1250 / 1500
Panel Weight	Nominal	[kg/m ²]	5.4 / 6.8 / 8.1

TECHNICAL PROPERTIES:

Rigidity		[kNcm ² /m]	500 / 1000 / 1700
Modulus of Elasticity	ASTM E8	[N/mm ²]	70000
Alloy of Cover Sheet	ASTM B 209		5005
Temper of Cover Sheets	ASTM B 209		H24
Tensile Strength of Aluminium	ASTM E8	[MPa]	≥ 145

SURFACE:

Lacquering			Coil Coating Pre coated PVDF/ Specially treated coating
Gloss (Initial Value)	ASTM D523		As per the color shade

DIMENSIONAL TOLERANCES:

Panel Thickness		[mm]	± 0.15mm
Weight		[mm]	± 10%
Length		[mm]	+ 6mm

*Specifications are subject to change without prior notice/intimation.

Fire Classification

COUNTRY	TEST ACCORD. TO ...	CLASSIFICATION
India	EN 13501-1	Class A2 - s1, d0
Australia / New Zealand	AS/NZS 1530.1	Passed

Sandwich Panel System

This system is developed based on ALUCORE®'s technology ideas. The system is composed of two layers of aluminium or steel sheets and a high-density non-combustible mineral wool sandwich layer.

Sandwich Panel System is provided with concealed installation accessories to meet

building's wind load, water tightness, airtightness, insulation and fire safety requirements. It is a functional wall system for buildings which integrates decoration, heat insulation and fire safety. Sandwich Wall System is widely applied in various large public facilities, industrial factories as well as regular buildings.

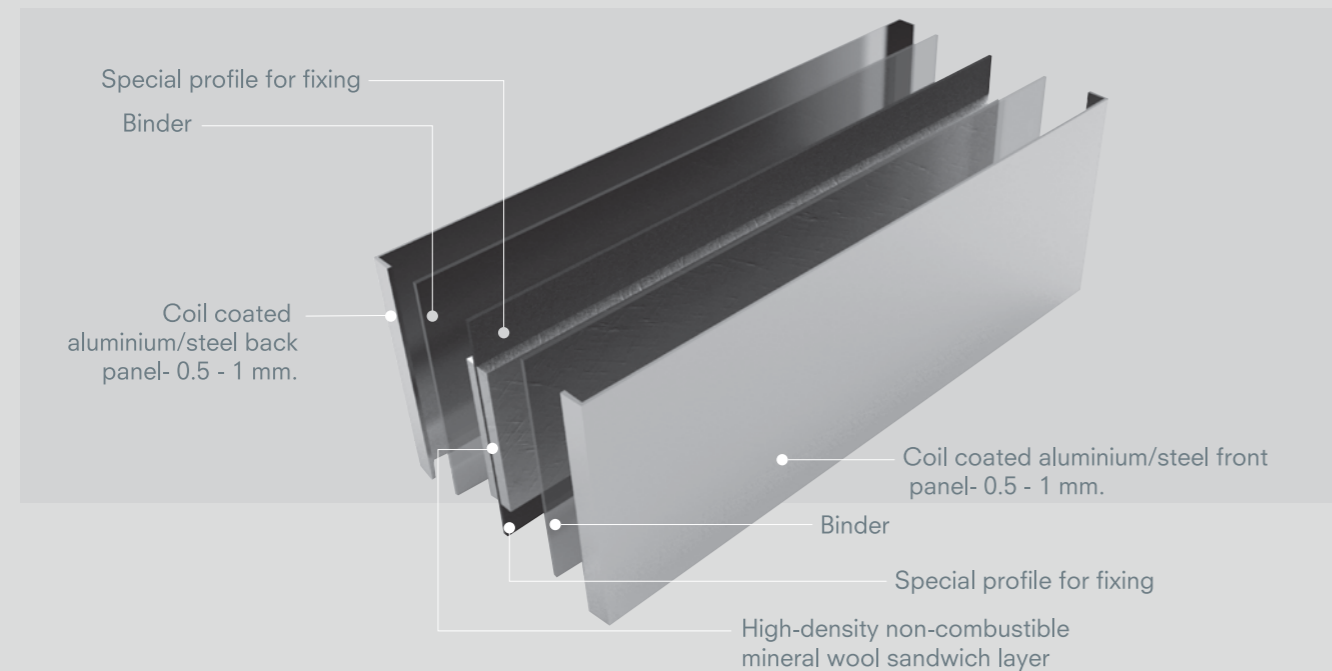

Sandwich Panel System Characteristics:

- Large panel size and even flatness
- Good thermal insulation performance - 30 times that of a traditional concrete construction, in both high and low temperatures
- Wide selection of product systems
- Simple and flexible installation
- Elegant joint design
- Fire safety - The product and the system has been tested to various country-specific standards, complying with all relevant building regulations.

Product Range:

- Sheets: Aluminium/steel - 0.5mm - 1mm
- Thickness: 35mm, 50mm, 60mm, 75mm, 100mm

3A Composites Sandwich Wall System

PRODUCT AND SPECIFICATIONS- IW		
Front / back Aluminium or Steel sheet	Materials	High-grade aluminium magnesium alloy AA5005, AA3003 or TDC51D+AZ (Steel)
Front Aluminium or Steel sheet	Thickness	0.6mm - 1.0mm (can be customised)
Back aluminium or Steel sheet		1.0mm / 0.7mm / 0.5mm / 0.4mm (can be customised)
Core material	Materials	High-density fireproof rock wool / AIREX® / BALTEK® (can be customised)
Baking finish system	Fluorocarbon	PVDF or FEVE
Dimensions	Length and breadth	Maximum panel size: 1500×6000mm
	Thickness	50mm / 100mm / 200mm* *custom thickness available. MOQ applies
Surface colour	ALUCOBOND® series standard colours available (*custom colors available. MOQ applies)	

Technical Data

SPECIFICATIONS	STANDARDS	UNIT	50 mm	100 mm
Panel-Thickness:				
Thickness of Steel plate		[mm]	Fs: 0.6mm; Rs 0.5mm	Fs: 0.7mm; Rs 0.5mm
Weight		[kg/m ²]	15	27
Grade of Steel plate			TDC51D+AZ	TDC51D+AZ
Tensile Strength	EN 485-2	[N/mm ²]	350-370	350-370
Elongation	EN 485-2	[%]	30	30
Yield Strength			280-300	280-300
Core:		[Kg/m ³]	120	120
Hydrophobic rate		[%]	≥98	≥98
Thermal resistance		m ² K/W	2.7	2.7
Acidity coefficient			1.8	1.8
Surface:			Coil Coating	Coil Coating
Coating			PVDF	PVDF
Gloss (initial value)	EN 13523-2	[%]	25-60	25-60
Pencil Hardness	EN 13523-4		HB	HB
Bending			3T	3T
Impact			9J	9J
Acoustical Properties:				
Sound Transmission Loss	GB/T 19889.3-2005	[dB]	30	25
Rw				
Thermal Properties:				
U Value		W/m K	0.74	0.37
R Value		W/m ² *K	1.35	2.7
		m ² *K/W		
Weather Tightness	GB/T21086-2007		Level 3	Level 3
Fire Classification	BS 476 Part 22 BS 476 Part 6&7 (core exposed)		Class 0	2 hour fire rating

*Specifications are subject to change without prior notice/intimation.

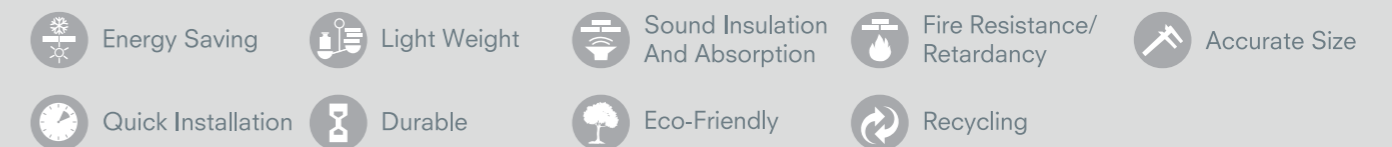

Product Range

Series	ALUCOBOND® A2	ALUCOBOND® PLUS	ALUCOBOND® FR	ALUCORE® HONEYCOMB
Solid Colours	●	●	●	●
Metallic Colours	●	●	●	●
Custom Colours	●	●	●	●
ALUCOBOND® colourscapes	●	●	●	●
ALUCOBOND® organics elegance	●	●	●	●
ALUCOBOND® anodized look	●	●	●	●
ALUCOBOND® concrete	●	●	●	●
ALUCOBOND® grove	●	●	●	●
Spectra & Sparkling	●	●	--	●
ALUCOBOND® naturAL	●	●	--	--
ALUCOBOND® EMBOSSSED LOOK	--	--	--	--
ALUCOBOND® terra	●	●	--	--
ALUCOBOND® urban	●	●	--	--
ALUCOBOND® wood look	●	●	--	--
ALUCOBOND® stone look	●	●	--	--
ALUCOBOND® legno	●	●	--	--
ALUCOBOND® design	●	●	--	--
ALUCOBOND® premium anodized	●	●	--	--
ALUCOBOND® rocca	●	●	--	--
ALUCOBOND® vintage	●	●	--	--

Series	ALUCORE® ACCP	ALUCOLUX®	ALUCODUAL®	SANDWICH PANEL SYSTEM
Solid Colours	●	●	●	●
Metallic Colours	●	●	●	●
Custom Colours	●	●	●	●
ALUCOBOND® colourscapes	●	●	●	--
ALUCOBOND® organics elegance	●	●	●	--
ALUCOBOND® anodized look	●	●	●	--
ALUCOBOND® concrete	●	--	●	--
ALUCOBOND® grove	●	--	●	--
Spectra & Sparkling	--	●	--	--
ALUCOBOND® naturAL	--	●	--	--
ALUCOBOND® EMBOSSSED LOOK	--	●	--	--
ALUCOBOND® terra	--	--	--	--
ALUCOBOND® urban	--	--	--	--
ALUCOBOND® wood look	--	●	--	--
ALUCOBOND® stone look	--	●	--	--
ALUCOBOND® legno	--	--	--	--
ALUCOBOND® design	--	--	--	--
ALUCOBOND® premium anodized	--	--	--	--
ALUCOBOND® rocca	--	--	--	--
ALUCOBOND® vintage	--	--	--	--

Disclaimer: Legno, Design and Vintage is only applicable for interior applications.

ALUCOBOND® A2 4mm | KNPC Petrol Filling Station - Sabah Al Ahmed City, Kuwait
 Architect: Pan Arab Consulting Engineers (PACE) | Fabricator: United Aluminium & Metal Coating Co.



ALUCORE® I Max Towers – Noida, India
 Architect: Gensler | Fabricator: Ashbee Industries India Pvt. Ltd.
 Photography: © Rohit Kumar



ALUCOBOND® PLUS | Porsche Zentrum - Dortmund, Germany
Architect: MUTABOR | Fabricator/Installer: Athens GmbH & Co. KG
Photography: © BRANDSPACEPHOTOGRAPHY - André Müller



Value Added Services

ALUCOBOND® has always tried to offer complete solutions to its customers apart from just world-class products.

Through Value Added Services (VAS) ALUCOBOND® goes a step further to ensure its customers get high-quality fabrication and finesse in the final output.

Whether the customer needs made to measure or ready to install or perforated panels, all could come directly from the factories of ALUCOBOND®.

With over 50 years of expertise, ALUCOBOND® has always been eager to help customers realise their designs.

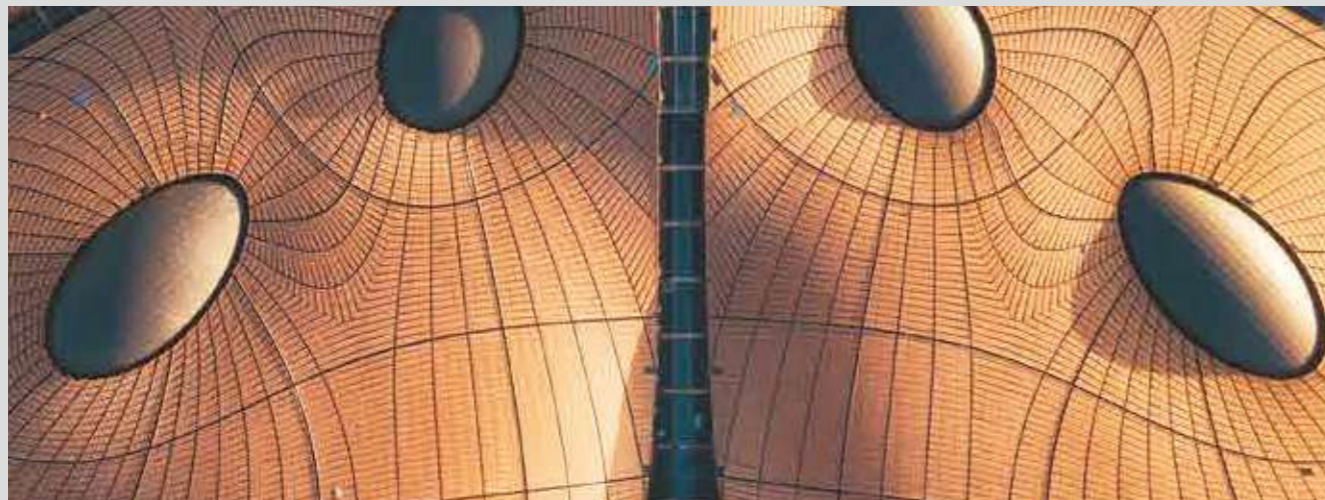

ALUCORE® CLAD | Daxing (Beijing) Airport - Beijing, China | Architect: Zaha Hadid Architects & ADP Ingenierie | Fabricator: Beijing Construction Engineering Group
Photography: Zhaoqi Li

ALUCOBOND® Ready to Install (R2I) Panels:

As the name suggests, R2I is a step further over the M2M service with folding and system assembly coming from the house of ALUCOBOND®. R2I allows for direct delivery at the job site. This ensures hassle-free installation and finishes in the end product.

ALUCOBOND® Perforation:

ALUCOBOND® also offers perforation service, where custom designs are realised according to each project's requirement. Skillful workmanship of ALUCOBOND® coupled with years of expertise ensures warrantable high-quality output.



ALUCOBOND® PLUS | Banyan Tree Residences Riverside - Bangkok, Thailand | Architect: SCDA Architects codesign with CAPA
Fabricator: Oregon Aluminium Co., Ltd. | Photography: Panoramic Studio

ALUCOBOND® Panel Optimization:

Panel Optimization is a process of computing the maximum panel utilization for a given facade elevation/ design/ layout by specially designed software. This service calculates the most efficient layout with accuracy in a short time. In doing so, wastages have been brought down to around 3-5% in most cases thereby allowing for saving costs to customers.

ALUCOBOND® Made to Measure (M2M) Panels:

ALUCOBOND® can manufacture tailor-made panels which are cut to size, routed, drilled and notched at the factory's production level to meet customers' specific requirements. This helps in high-quality fabrication and warrants a smooth transition from flat sheet to final product.

ALUCOBOND® Solar Shading Solutions:

In this service, ALUCOBOND® designs and optimises Solar Shading Solutions for you. This begins with calculation of Sun's path for each elevation and results in custom shading solutions that gives protection and balances unobstructed views. Based on these calculations ALUCOBOND® suggests the following:

- Vertical/horizontal fins.
- Fixed/adjustable fins.
- Size of the fins to optimize sun light and to withstand the wind load.
- Right product for the right application along with the correct fixing mechanism.

Fixing Systems

Tray Panel

This system is one of the most adaptable systems for facade cladding with either vertical or horizontal panel layouts. Individual panels are of a tray/cassette type, with four sides folded and framed with extruded aluminium profile sections. Individual elements are fastened to an extruded aluminium sub-structure by means of aluminium profiled cleats, which in turn are anchored to the wall. The horizontal and vertical joints between the panels are of minimum 15 mm width and all rivets, fastening cleats and screws are concealed within it and kept closed by a profiled strip of matching or contrasting colour.

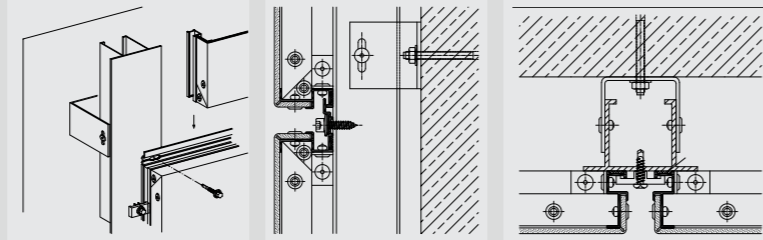

SZ-20

This system assembly is based on the 'tongue and groove' principle and is particularly suited for facade cladding with a horizontal panel layout. Individual panels are folded into a tray and the top and bottom sides are grasped by an extruded aluminium section. The 'Z' and 'S' profiles are riveted to the top and bottom folded edge of the panels respectively, facilitating the 'tongue and groove' assembly. The vertical folded edges are riveted with the 'S' profiles that facilitate fixing with aluminium profiled cleats to the 'Hat' profiled sub-structure. All the rivets, fastening cleats and screws are concealed within the panels.

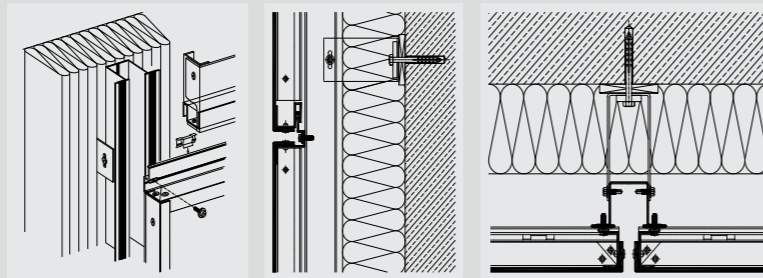

Hook-on

The ALUCOBOND® Hook-on system is an open-joint rear ventilated system with a vertical panel layout. This system facilitates unimpeded movements of the elements in all aspects, as well as allowing the joint widths between the panels to be as narrow as 6 mm.

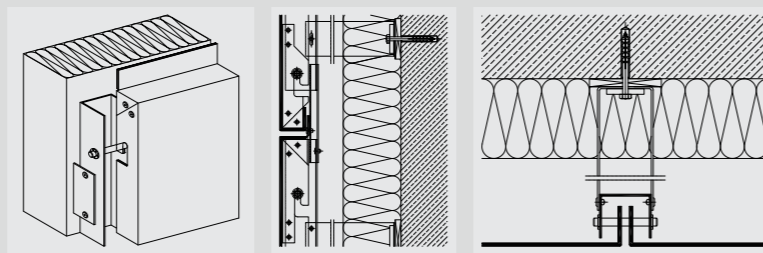

Easy fiX

Easy fiX system is a hybrid solution between face fixed panels and cassette solutions. Panels can be installed in horizontal or vertical layout. Easy fiX offers simple clamping without adding rivets reducing the cassette thickness to 31 mm, hence allows compact design.

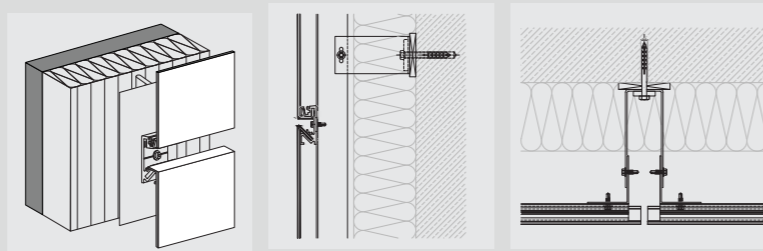

Easy fiX tray panels are simply made with 2 types of milling lines that give 3 types of panels viz easy fiX 90°/135°, easy fiX 135°/135°, easy fiX 90°/90°.

Useful Information

Installation

To avoid possible reflection differences (for metallic, special effect, naturAL and spectra colours), it is recommended to install the panels in the same direction as marked on the protective peel-off-film.

Colour variations may occur between panels originating from different production batches. To ensure colour consistency, the total requirement for a project should be placed in one order.



ALUCOBOND® PLUS I Lauridsen Amphitheater, Des Moines, USA
 Architect : RDG Planning & Design | Fabricator : Metal Design System Inc.; The Waldinger Corp.
 Photography: © Joe Crimmings

Protective Film

In order to avoid adhesive residues on the surface, caused by UV radiation, the protective film should be removed as soon as possible after the panels have been installed. Protective films and panel surfaces are not to be marked with inks (felt tips), adhesive tapes or stickers, as solvents or softeners can damage the painted surfaces. After installation, the protective film must be removed as quickly as possible, as films which has been weathered on a long-term basis can only be removed with great difficulty.

Storage / Handling

ALUCOBOND® should be protected against rain, dampness penetrating the panels and the build-up of condensation. It is recommended that panels of the same dimension and size must be stacked with a maximum stacking height of 6 pallets. Storage for more than 6 months should be avoided as removing the film may not be easy. When stacking, do not lay anything between the panels to avoid imprints.

Warranty

ALUCOBOND® stands for high quality and durability. Warranties according to the product specification and approved field of application can be obtained upon request.

Cleaning and Maintenance

The frequency of cleaning and the choice of a suitable cleaning agent depends largely on the location of the building and the condition of the panel surface. The cleaning can be carried out with water and a sponge or a soft brush. In case of severe soiling add a neutral detergent.

ALUCOBOND® | Orona Zero – Hernani, Spain
Architect: Barrutieta, Goikoetxea, de la Fuente & Perez | Fabricator: Uxama Fachadas Singulares, Biscay
Photography: © Agustín Sagasti



Infinite Possibilities

3A Composites is listening to the needs of architects, consultants, developers, fabricators and installers. Thousands of projects worldwide serve as an inspirational starting point in the planning process of any construction. Furthermore, 3A Composites excels at sharing its know-how with customers and offer comprehensive advice for every step of the building process.